

TRIUMPH

REPLACEMENT PARTS

CATALOGUE No. 16

FOR

6T — THUNDERBIRD

TR6 — TROPHY

T120 — BONNEVILLE 120

From Eng No 029364 & D 101 onwards

Sept 1960

TRIUMPH ENGINEERING CO. LTD., MERIDEN WORKS

ALLESLEY, COVENTRY, ENGLAND

PREFACE

BEFORE ordering parts for your machine, please read very carefully the instructions contained in the next paragraph. In a large number of cases, the information given in orders is not sufficient to enable us to identify customers' requirements with certainty. Delay is frequently occasioned by our having to refer the order back for further particulars before we can supply.

HOW TO ORDER. Every part is indicated by number, and this should be quoted together with the description. In order to assist customers, dimensions have been given in many cases where parts are similar. Parts where possible have been listed in order of assembly and a number of the illustrations show the assembly order also. With these aids there should be no difficulty in identifying the parts you require. **Always head your order with the engine number, stamped on the left side of the crank case underneath the cylinder flange, together with the prefix letters.** Use a separate sheet for your order if you are sending a letter as well.

SPECIMEN ORDER

	25/11/60
To Triumph Engineering Co. Ltd., Spares Department, Meriden Works, Allesley, Coventry.	
Engine No. 6T-D1562	
Please supply :—	
1 - CP.98/20	- Piston Assy. + .020"
1 - E2899	- Guide, inlet valve
*Send C.O.D.	
	Wm. Smith, 1a, Ewell Avenue, Ewell, Surrey.

**For terms of business see page 4.*

TELEGRAPHIC ORDERS. Orders by telegram should be addressed to "Trusty 20221 Coventry". They are then telephoned to us, which prevents delay in delivery. It is only necessary to quote part numbers in telegraphic orders, the description can be omitted.

PATTERNS AND PARTS FOR REPAIR. It is not necessary to send patterns if the part number is quoted. The sending of patterns often delays the order as parcel post or rail takes longer than letter post.

Parts sent to Coventry for repair, replacement or as patterns should bear the sender's name and address and clear instructions should accompany the parts. All parts must be forwarded carriage paid and care should be taken to ensure that all remittances are sent separately and not enclosed with the parts. Fragile units such as cylinders, etc., should always be boxed to avoid damage in transit. Complete machines should have all fitments such as windscreens, driving mirrors, tools, etc., removed by the sender before despatch, as it is impossible for us to accept responsibility in the event of loss in transit. We are always pleased to give estimates for overhauling and repairs, but should an estimate not be accepted, a charge will be made covering cost of dismantling and re-assembling, if carried out.

Communications relating to Parts should be addressed to the SPARES MANAGER and for repairs, guarantee claims and technical advice to the SERVICE MANAGER, Triumph Engineering Co. Ltd., Meriden Works, Allesley, Coventry. In order to facilitate quick reference, the quoting of any number, invoice number or reference from previous communications is of essential importance. Accessories not of our manufacture should be sent direct to the actual makers, whose names and addresses appear on Page 4.

WHERE TO OBTAIN. Triumph Spare Parts may be obtained from any Triumph Dealer, and we recommend our customers to place their orders with the Triumph Dealer in their district, as we do not normally supply direct. When parts not usually asked for are required, and for which the Dealer may have to write or obtain specially, the postage or carriage incurred becomes payable.

We are not able to supply Transfers as originally affixed to Triumph Motor Cycles, but we are at all times willing to supply a transfer denoting that the machine is of genuine Triumph manufacture, provided the Frame and Engine prefix letters and numbers are quoted.

Customers are warned against the risk incurred by purchasing parts that are not of genuine Triumph manufacture. This risk is eliminated if parts are ordered as instructed, either from recognised Dealers, or direct from the Spares Department, Meriden Works, Allesley, Coventry.

TERMS OF BUSINESS

THE most convenient method of paying for Spare Parts is by the C.O.D. system. By this method you pay the postman for the goods when he delivers them to you. As the minimum C.O.D. collection fee is 1/2, only goods to the value of 2/- and over can be sent by this system. We do not despatch goods by rail C.O.D.

Where goods are not sent C.O.D., cash must accompany the order. All remittances should be made payable to the Triumph Engineering Co. Ltd., and crossed "Barclay's Bank Ltd." if in the form of Postal Order or cheque. Letters containing currency notes must be registered.

Should a remittance be forwarded by telegraphic money order, the name and address of the sender must be inserted in the space provided on the Post Office requisition form for a private message from remitter to payee. Unless this is complied with the Post Office omit such information from the telegram and we are not then in a position to trace the sender.

Postage, carriage and packing is charged at 5% on the value of the goods, minimum charge 1/-. Packing boxes, cases, crates, etc., are charged for at cost and are returnable.

PROPRIETARY GROUP

Ancillary equipment which is fitted to our motor cycles is of the highest quality and is guaranteed by the manufacturers and not by ourselves. Any repairs or claims should be made to the actual makers or their local agents who will always give owners every possible assistance. The following are the addresses of the various manufacturers :—

CARBURETTERS.

Messrs. Amal Ltd.,
Holdford Road, Witton, Birmingham, 6.

CHAINS.

Renold Chains Ltd.,
Wythenshawe, Manchester.

ELECTRICAL EQUIPMENT.

Messrs. J. Lucas Ltd.,
Gt. Hampton Street, Birmingham, 18.

TYRES.

Dunlop Rubber Co. Ltd.,
Fort Dunlop,
Birmingham, 24.

SPARKING PLUGS.

Champion Sparking Plug Co. Ltd.,
Feltham, Middlesex.

K.L.G. Sparking Plugs Ltd.,
Cricklewood Works, London, N.W.2.

Lodge Plugs Ltd.,
Rugby, Warwickshire.

SPEEDOMETERS.

Messrs. Smiths Motor Accessories Ltd.,
Cricklewood Works, London, N.W.2.

SUSPENSION UNITS.

Messrs. Girling Ltd.,
Kings Road, Tyseley, Birmingham, 11.

TRIUMPH GUARANTEE

1. In this Guarantee the word "machine" refers to the motor cycle, scooter, motor cycle combination or sidecar as the case may be, purchased by the Purchaser.
2. In order to obtain the benefit of this Guarantee, the Purchaser must have correctly completed the registration form and returned it to us within fourteen days of the purchase.
3. We will supply, free of charge, a new part in exchange for, or, if we consider repair sufficient, will repair free of charge any part proved within six months of the date of purchase of any new machine, (three months overseas) or within three months of its renewal or repair in the case of a part already renewed or repaired, to be defective by reason of our faulty workmanship or materials. We do not undertake to bear the cost of fitting such new or repaired part or accessory.
4. Any part considered to be defective must be sent to our Works, carriage paid, accompanied by the following information :—
 - (a) Name of purchaser and his address ;
 - (b) Date of purchase of machine ;
 - (c) Name of dealer from whom the purchase was made ;
 - (d) Engine number and model.
5. This Guarantee shall not extend to defects or damage appearing after misuse, neglect, abnormal stress or strain, or the incorporation or affixing of unsuitable attachments or parts and in particular :—
 - (a) Hiring out ;
 - (b) Racing and Competitions ;
 - (c) Adaptation or alteration of any part or parts after leaving our Works ;
 - (d) The attaching of a sidecar in a manner not approved by us or to an unsuitable motor cycle.

This Guarantee shall not extend to machines whose trade mark, name or manufacturing number has been altered or removed, or in which has been used any part not supplied or approved by us, or to tyres, saddles, chains, speedometers, revolution counters and electrical equipment or to parts supplied to the order of the Purchaser and different from our standard specification.
6. Our liability and that of our dealer who sells the machine, shall be limited to that set out in this guarantee, and no other claims including claims for consequential damage or injury to person or property, shall be admissible. All other conditions and warranties statutory or otherwise and whether express or implied are hereby excluded and no guarantee other than that expressly herein contained applies to the machine to which this Guarantee relates or any accessory or part thereof.
7. We reserve the right to modify or deviate from the Published Specification without notice.

REPAIRS GUARANTEE

1. Whilst the highest standard of workmanship and materials is aimed at, we cannot accept liability for any defects appearing more than three months after the machine, assembly or component has left our Works after being repaired.
2. We will repair or replace at our option free of charge any defective work, materials or parts relating to the repairs carried out by us appearing within that time but shall not be under any further or other liability for any other loss or damage whether direct or consequential and our liability shall be limited to the cost of so making good. We do not undertake to bear the cost of fitting any replacement or repaired part.
3. We do not accept liability in respect of parts of proprietary manufacture, e.g. tyres, saddles, chains, speedometers, revolution counters and electrical equipment which may be used by us in effecting a repair. All other conditions and warranties statutory or otherwise express or implied are hereby excluded.

ILLUSTRATION INDEX

Fig. No.		Page No.
1	Crankshaft and Connecting Rods	16
2	Crankcase	18
3	Oil pump and Release valve and Manifold	20
4	Cylinder block and head, 6T	22
5	Cylinder block and head, T110 and TR6	24
6	Cylinder block and head, T120	26
7	Gearbox and casing	28
8	Gearbox shafts and gears	30
9	Gearbox selector mechanism	32
10	Clutch	34
11	Frame	36
12	Swinging fork and suspension units	38
13	Engine and gearbox fittings	40
14	Chaincase and alternator	42
15	Exhaust pipes and silencers	44
16	Telescopic Front Fork, 6T and T110	46
17	Nacelle, headlamp and switches	48
18	Telescopic Front Fork, TR6 and T120	50
19	Front Wheel, 6T	52
20	Front Wheel, T110, TR6 and T120	54
21	Rear Wheel	56
22	Quickly detachable Rear Wheel	58
23	Petrol Tanks	60
24	Oil Tanks	62
25	Battery Carrier and Air Filter	64
26	Mudguards	66
27	Panels and Twinseats	68
28	Handlebars	70
29	Control Cables and American Handlebars	72
30	Tool Kit, Frame Lock, Pillion Footrest and Licence Holder	74
31	Carburetter 6T, T110 and TR6	76
32	Bonneville 120 Carburetters	78
33	Bonneville 120 Float Chamber	80
34	Magneto with Automatic Advance and Retard	82
35	Magneto with Manual Control	84
36	Distributor and Coil	86
37	Headlamp and Wiring Harness, TR6 and T120	88
38	Speedometer, Tail Lamp and Rectifier	90

INDEX

	<i>Page No.</i>		<i>Page No.</i>
AIR FILTER	64	MAGNETO	82, 84
ALTERNATOR	42	MUDGUARDS	66
BATTERY CARRIER	64	NACELLE	48
CARBURETTER	76, 78, 80	OIL PUMP	20
CARTON PACKS	12	OIL TANK	62
CENTRE STAND	36	PETROL TANK	60
CHAIN CASE	42	PILLION FOOTRESTS	74
CHAINS	42	PISTONS	16
CLUTCH	34	PROP STAND	36
COIL	86	Q.D. REAR WHEEL	58
CONTROL CABLES	72	REAR PANELS	68
CONTROL LEVERS	70	REAR WHEEL	56
CRANKCASE	18	RECTIFIER	90
CRANKSHAFT	16	SILENCERS	44
CYLINDER HEAD	22, 24, 26	SPARKING PLUGS	82, 84, 86
DISTRIBUTOR	86	SPEEDOMETER	90
ENGINE PLATES	40	STEERING RACES	36, 46, 50
ENGINE SPROCKET	16	SUSPENSION UNITS	38
EXHAUST PIPES	44	SWITCHES	48, 88
FOOTRESTS	40	TIMING GEARS	16
FRONT FORKS	46, 50	TOOLKIT	74
FRONT WHEEL	52, 54	TWINSEAT	68
GASKET SETS	14	VALVES	22, 24, 26
GEARBOX	28, 30, 32	WIRING HARNESS	48, 88
HANDLEBARS	70, 72		
HORN	48, 88		
SUPPLEMENT SHEETS WITH EFFECT FROM ENGINE No. D.7727			93

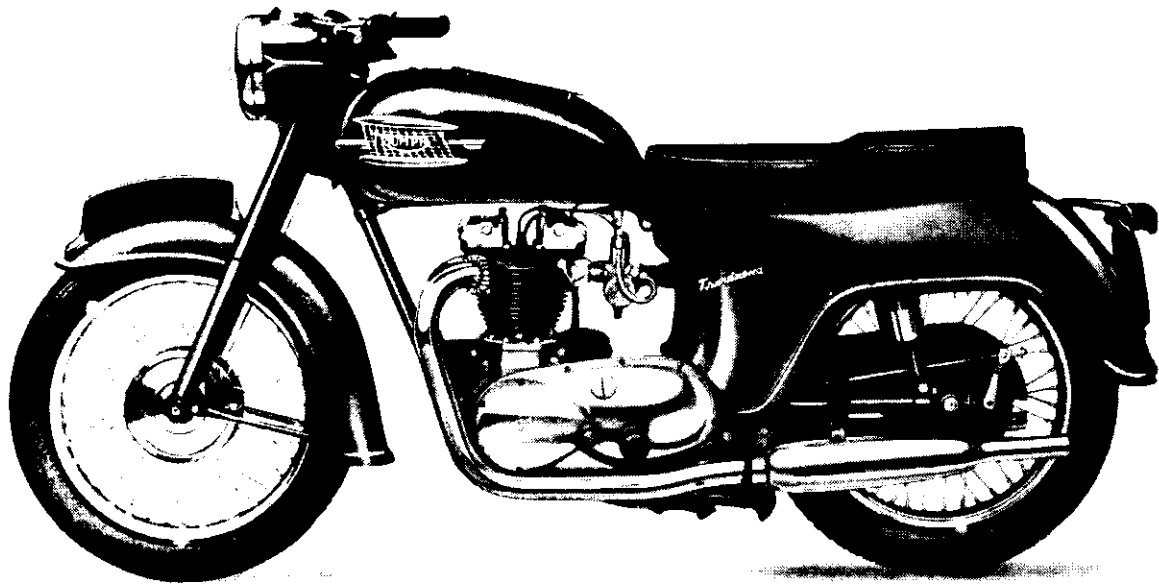

THUNDERBIRD (6T) TECHNICAL DATA

Bore and stroke	71 × 82 mm. 2.79 × 3.23 ins.
Capacity	649 c.c. (40 cu. ins.)
Compression ratio	7 : 1
Sparking plugs	Champion L7, K.L.G. F.80 or Lodge H.14
Carburetter	Amal Monobloc 376
					Main jet	270
					Needle jet	1065
					Needle	Type C
					Throttle valve	376/3½
					Pilot jet	25
Engine sprocket	Solo	23 teeth
				Sidecar	20 teeth
Chains	Front	½" × ⅝" × 70 links
				Rear	⅝" × ⅜" × 98 links
Capacities	Fuel Tank	4 galls. (18 litres)
				Oil Tank	5 pints (2.8 litres)
				Gearbox	⅔ pint (400 c.c.)
				Primary Chaincase	¼ pint (150 c.c.)
				Front Forks (each leg)	¼ pint (150 c.c.)
Brakes	Front and rear diameter	7" (17.78 cms.)
Tyre size	Front	3.25 × 18
				Rear	3.50 × 18

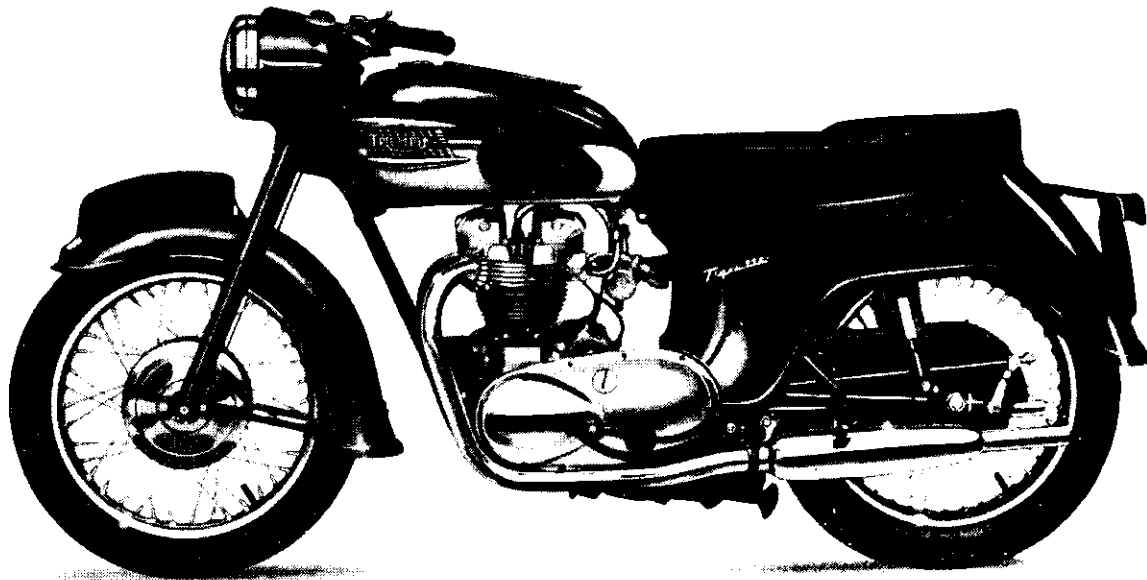

TIGER 110 (T110) TECHNICAL DATA

Bore and stroke	71 × 82 mm. 2.79 × 3.23 ins.
Capacity	649 c.c. (40 cu. ins.)
Compression Ratio	8 : 1
Sparking Plugs	Champion N3, K.L.G. FE.100 or Lodge HLN
Carburetter	Amal Monobloc 376
										Main Jet ... 250
										Needle jet ... 1065
										Needle ... Type C
										Throttle valve ... 376/3½
										Pilot jet ... 25
Engine sprocket							Solo ... 23 teeth
										Sidecar ... 20 teeth
Chains							Front ... ½" × 5/16" × 70 links
										Rear ... ½" × 3/8" × 98 links
Capacities							Fuel Tank ... 4 galls. (18 litres)
										Oil Tank ... 5 pms (2.8 litres)
										Gearbox ... 3/8 pint (400 c.c.)
										Primary Chaincase ... ½ pint (150 c.c.)
										Front Forks (each leg) ... ½ pint (150 c.c.)
Brakes							Front diameter ... 8 in. (20.32 cm.)
										Rear diameter ... 7 in. (17.78 cm.)
Tyre size							Front ... 3.25 × 18
										Rear ... 3.50 × 18

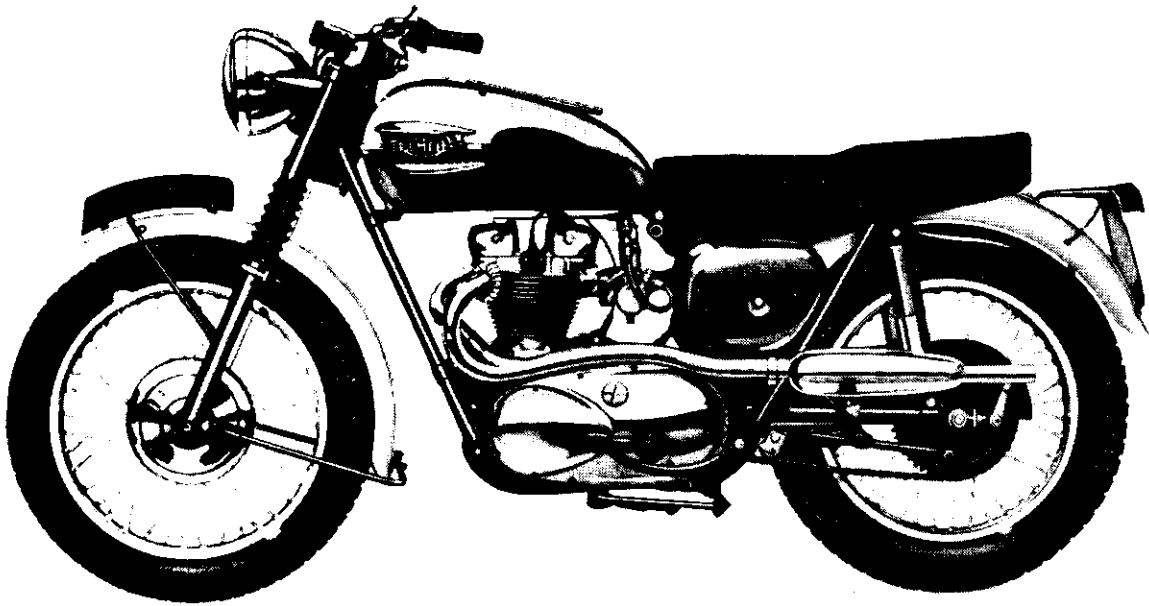

TROPHY (TR6) TECHNICAL DATA

Bore and stroke	71 × 82 mm. 2.79 × 3.23 ins.
Capacity	649 c.c. (40 cu. ins.)
Compression ratio	8 : 1
Sparking plugs	Champion N3, K.L.G. FE.100 or Lodge HLN
Carburetter	Amal Monobloc 376
											Main jet ... 250
											Needle jet ... 1065
											Needle ... Type C
											Throttle valve ... 376/3½
											Pilot jet ... 25
Engine sprocket	22 teeth
Chains	Front ... ½" × ⅝" × 70 links
											Rear ... ⅝" × ⅜" × 98 links
Capacities	Fuel Tank ... 3 galls. (13.5 litres)
											Oil Tank ... 5 pints (2.8 litres)
											Gearbox ... ⅔ pint (400 c.c.)
											Primary Chaincase ... ¼ pint (150 c.c.)
											Front Forks (each leg) ... ¼ pint (150 c.c.)
Brakes	Front diameter ... 8 in. (20.32 cm.)
											Rear diameter ... 7 in. (17.78 cm.)
Tyre size	Front ... 3.25 × 19
											Rear ... 4.00 × 18

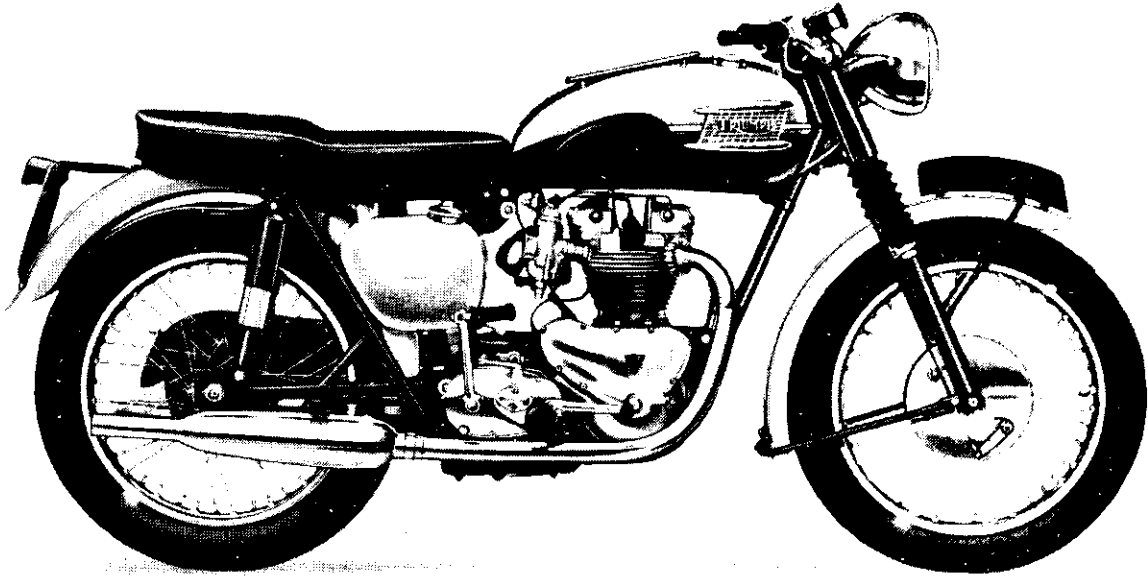

BONNEVILLE 120 (T120) TECHNICAL DATA

Bore and stroke	71 × 82 mm. 2.79 × 3.23 ins.
Capacity	649 c.c. (40 cu. ins.)
Compression ratio	8.5 : 1
Sparking plugs	Champion N3, K.L.G. FE.100 or Lodge HLN
Carburetters	2 Amal Monobloc 376
	Main jet 240
	Needle jet 1065
	Needle Type
	Throttle valve 376/3½
	Pilot jet 25
Engine sprocket	22 teeth
Chains	Front ½" × 5/16" × 70 links
	Rear 5/8" × 3/8" × 98 links
Capacities	Fuel Tank 4 galls. (18 litres)
	Oil Tank 5 pints (2.8 litres)
	Gearbox 3/8 pint (400 c.c.)
	Primary Chaincase ½ pint (150 c.c.)
	Front Forks (each leg) ½ pint (150 c.c.)
Brakes	Front diameter 8 in. (20.32 cm.)
	Rear diameter 7 in. (17.78 cm.)
Tyre size	Front 3.25 × 19
	Rear 3.50 × 19

CARTON PACK LIST

The following sub-assemblies are supplied in carton packs under the C.P. part number stated. The contents of these carton packs are preserved and will not deteriorate under adverse conditions.

Part No.			Contents
Brake Lining			
C.P.38/A.M.2	...	2	NW243 Brake lining
		16	W129 Rivet
C.P.66/A.M.2	...	2	W1336 Brake lining
		16	W129 Rivet
Crankcase Bearing			
C.P.144	...	2	E1591 Ball journal bearings.
Fork Service Pack			
C.P.168	...	2	H420 Rubber washer
		4	H430 Fibre washer
		2	H441 Upper bearing
		2	H443 Lower bearing
		2	H1062 Aluminium washer
		2	H1168 Oil seal
Standard Ratio Gears (to convert from Wide Ratio)			
C.P.145	...	1	T1382 Mainshaft high gear
		1	T916 Mainshaft second gear
		1	T1063 Layshaft and high gear
		1	T1065 Layshaft second gear
		1	T934 Speedometer driven gear
Wide Ratio Gears (to convert from Standard Ratio)			
C.P.94	...	1	T1384 Mainshaft high gear
		1	T968 Mainshaft second gear
		1	T971 Layshaft and high gear
		1	T974 Layshaft second gear
		1	T975 Speedometer driven gear
Close Ratio Gears (to convert from Standard Ratio)			
C.P.95	...	1	T1177 Mainshaft and low gear
		1	T1383 Mainshaft high gear
		1	T1179 Mainshaft third gear
		1	T955 Mainshaft second gear
		1	T959 Layshaft and high gear
		1	T964 Layshaft third gear
		1	T963 Layshaft second gear
		1	T961 Layshaft low gear
		1	T1227 Blanking cap

CARTON PACK LIST — continued

Part No.									Contents
Kickstarter Ratchet Set									
C.P.27	1	T730	Kickstarter pinion
			1	T731	Kickstarter ratchet
			1	T1250	Ratchet spring
			1	T1338	Sleeve
			1	T732	Tab washer
Pistons									
C.P.158	1	E3611	Piston C.R. 6-3 : 1
			2	E3049	Compression ring
			1	E2898	Oil control ring
			1	WE203E	Gudgeon pin
			2	WE479	Circlip
C.P.98 (6T only)	...		1	E2891	Piston C.R.7 : 1
			2	E3049	Compression ring
			1	E2898	Oil control ring
			1	WE203E	Gudgeon pin
			2	WE479	Circlip
C.P.98 is also available in 0-010 in. and 0-020 in. oversizes									
C.P.159	1	E3612	Piston C.R. 7-5 : 1
			2	E3049	Compression ring
			1	E2898	Oil control ring
			1	WE203E	Gudgeon pin
			2	WE479	Circlip
C.P.159 is also available in 0-010 in. and 0-020 in. oversizes									
C.P.163	1	E3670	Piston C.R. 8 : 1
			2	E3049	Compression ring
			1	E2898	Oil control ring
			1	WE203E	Gudgeon pin
			2	WE479	Circlip
C.P.163 is also available in 0-010 in. and 0-020 in. oversizes									
C.P.157	1	E3610	Piston C.R. 8-5 : 1
			2	E3049	Compression ring
			1	E2898	Oil control ring
			1	WE203E	Gudgeon pin
			2	WE479	Circlip
C.P.157 is also available in 0-010 in. and 0-020 in. oversizes									
C.P.160	1	E3613	Piston C.R. 12 : 1 (Alcohol fuel)
			2	E3049	Compression ring
			1	E2898	Oil control ring
			1	WE203E	Gudgeon pin
			2	WE479	Circlip

CARTON PACK LIST—continued

Part No. _____ **Contents**

Piston Rings

C.P.99	4	E3049	Compression ring
				2	E2898	Oil control ring

C.P.99 is also available in 0-010 in. and 0-020 in. oversizes

Valves

C.P.96 (6T)	2	E2903	Inlet valve
			2	E2904	Exhaust valve

C.P.173	2	E3310	Inlet valve
(T110, TR6, T120)			2	E3927	Exhaust valve

Valve Guides

C.P.97	2	E2899	Inlet guide
(6T, T110, TR6)			2	E2900	Exhaust guide

Valve Springs

C.P.5	4	E1488	Inner spring
(6T, T110, TR6)			4	E1487	Outer spring

C.P.102	4	E3001	Inner spring
(T120)			4	E3002	Outer spring

Steering Races

C.P.156	2	H111	Cups
			1	H439	Cone
			1	H1018	Top cone and dust cover
			40	S70-3	Balls

Tachometer Drive (TR6 and T120)

C.P.181	1	E4167	Cover
			1	E2749	Driven gear
			2	E3678	Grub screw
			1	E3679	Driving gear housing
			1	E3682	Driven gear housing
			1	E3686	Driving gear
			1	E3685	Exhaust camshaft nut
			1	52091/5	Drive cable
			1	H1083	Mounting bracket
			2	H1086	Bolts
			1	RC109	Tachometer head

GASKET SETS

6T	GS. 6T/56
T110 and TR6	GS. T110/56
T120	GS. T120/59

PLEASE NOTE

THROUGHOUT THIS LIST, ASSEMBLIES ARE PRINTED IN CAPITALS AND THE COMPONENTS INCLUDED IN THAT ASSEMBLY ARE INDENTED IN THE DESCRIPTION COLUMN, REVERTING TO THE ORIGINAL ALIGNMENT WHEN THE ASSEMBLY IS COMPLETE. TO ORDER THE COMPLETE ASSEMBLY IT IS NECESSARY ONLY TO QUOTE THE ASSEMBLY NUMBER. ANY COMPONENT PARTS LISTED MAY ALSO BE OBTAINED SEPARATELY, IF REQUIRED.

SPECIAL WORKSHOP TOOLS

A COMPLETE LIST OF WORKSHOP TOOLS CAN BE MADE AVAILABLE BY EITHER CONTACTING YOUR DEALER OR APPLYING DIRECT TO THE TRIUMPH SERVICE DEPARTMENT. IN MOST CASES THESE TOOLS ARE VERY COSTLY AS THEY ARE MADE ENTIRELY FOR WORKSHOP USE, AND THEREFORE, IT IS NOT RECOMMENDED THAT THE PRIVATE OWNER PURCHASES THE TOOLS IN ORDER TO AID SERVICING THE MACHINE ONCE OR TWICE ONLY. IN THESE CIRCUMSTANCES IT IS FAR MORE ECONOMICAL TO GET IN TOUCH WITH A RECOGNISED DEALER.

**Crankshaft and
flywheel assembly
Ref. No. 1.**

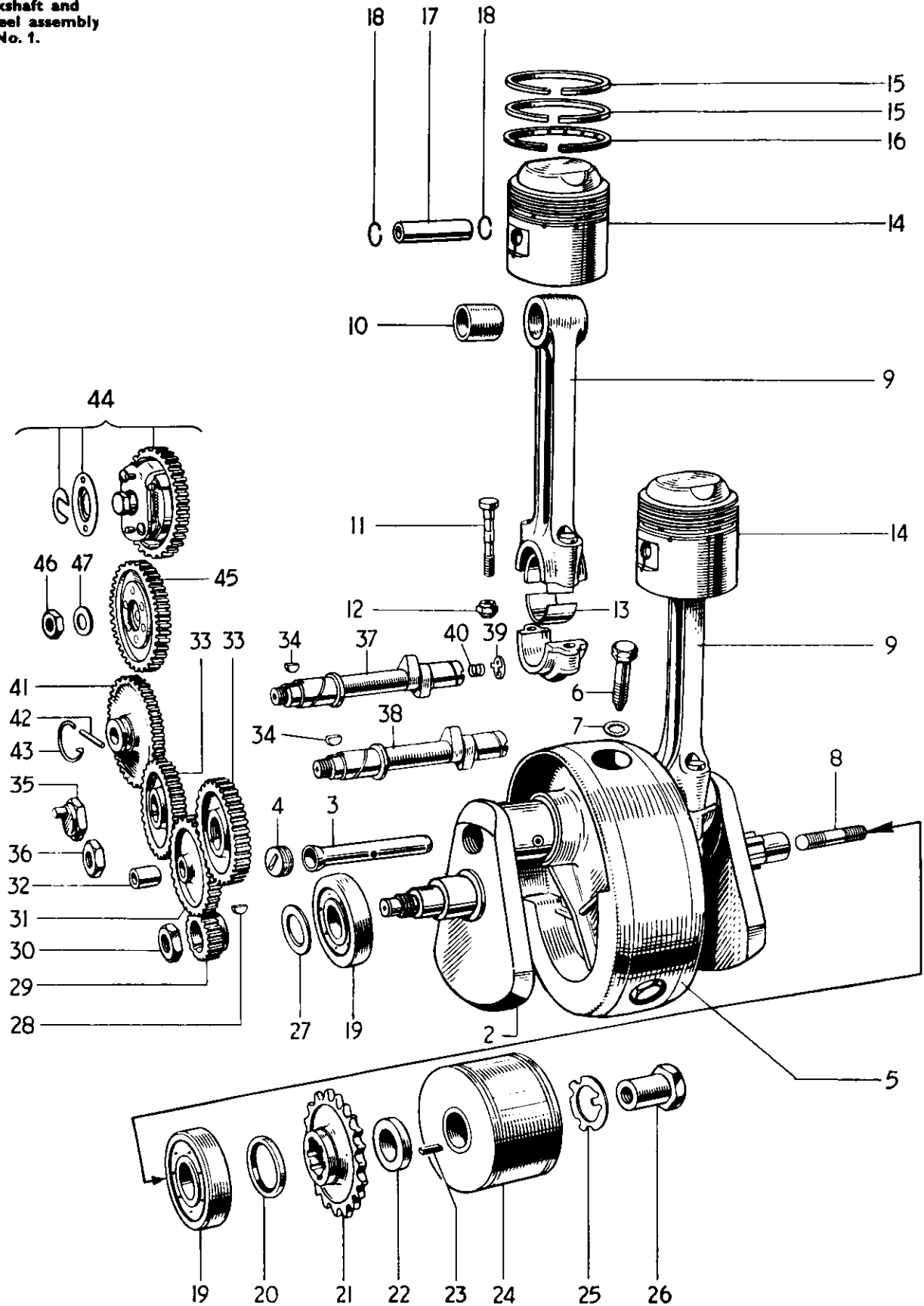

FIG. 1 CRANKSHAFT AND CONNECTING RODS

CRANKSHAFT AND CONNECTING RODS

			6T	T110	TR6	T120
1	E3893	CRANKSHAFT AND FLYWHEEL ASSEMBLY	1	1	1	1
2	E3894	CRANKSHAFT c/w OIL TUBE	1	1	1	1
3	E3903	Oil tube	1	1	1	1
4	E3905	Screwed plug	1	1	1	1
5	E3906	Flywheel	1	1	1	1
6	E3907	Flywheel bolt	3	3	3	3
7	E2288	Serrated washer	3	3	3	3
8	E3114	Crankshaft stud (1 $\frac{3}{16}$ " O.A.)	1	1	1	1
9	E3606	CONNECTING ROD	2	2	2	2
10	E1511	Small end bush	2	2	2	2
11	E2490A	Connecting rod bolt	4	4	4	4
12	E2922	Self locking nut	4	4	4	4
13	E3586	Big end bearings	4	4	4	4
14	CP98	PISTON COMPLETE 7 : 1 C.R.	2	-	-	-
14	CP163	PISTON COMPLETE 8 : 1 C.R.	-	2	2	-
14	CP157	PISTON COMPLETE 8 · 5 : 1 C.R.	-	-	-	2
15	E3049	Taper compression ring	4	4	4	4
16	E2898	Oil control ring	2	2	2	2
17	WE203E	Gudgeon pin	2	2	2	2
18	WE479	Circlip	4	4	4	4
19	E1591	Main bearing	2	2	2	2
20	H1168	Oil seal	1	1	1	1
21	E3108/23	Engine sprocket (solo)	1	1	-	-
21	E3108/20	Engine sprocket (sidecar)	A	A	-	-
21	E3108/22	Engine sprocket (solo)	-	-	1	1
22	E3116	Backing washer	1	1	1	1
23	E3974	Rotor key	1	1	1	1
24	423506	Rotor	1	1	1	1
25	E3975	Tab washer	1	1	1	1
26	E3977	Nut	1	1	1	1
27	E3300	Clamping washer	1	1	1	1
28	E1580	Key	1	1	1	1
29	E1472	Timing pinion	1	1	1	1
30	E398	Nut	1	1	1	1
31	E1471	INTERMEDIATE WHEEL	1	1	1	1
32	E400	Intermediate wheel bush	1	1	1	1
33	E1486A	Camshaft wheel	2	2	2	2
34	E1558	Camshaft key	2	2	2	2
35	E1463	Inlet camshaft nut	1	1	1	1
36	E1492	Exhaust camshaft nut	1	1	1	1
37	E3275	Inlet camshaft	1	-	-	-
37	E3325	Inlet camshaft	-	1	1	-
37	E3134	Inlet camshaft	-	-	-	1
38	E3275	Exhaust camshaft	1	-	-	-
38	E3325	Exhaust camshaft	-	1	1	1
39	E2254	Rotary breather valve	1	1	1	1
40	E2256	Breather valve spring	1	1	1	1
41	E3123	Distributor pinion	1	-	-	-
42	E3125	Pin	1	-	-	-
43	E3126	Circlip...	1	-	-	-
44	47502	Auto-advance unit	-	1	-	1
45	E2741	Magneto pinion	-	-	1	-
46	170104	Magneto pinion nut	-	-	1	-
47	E1330	Plain washer	-	-	1	-

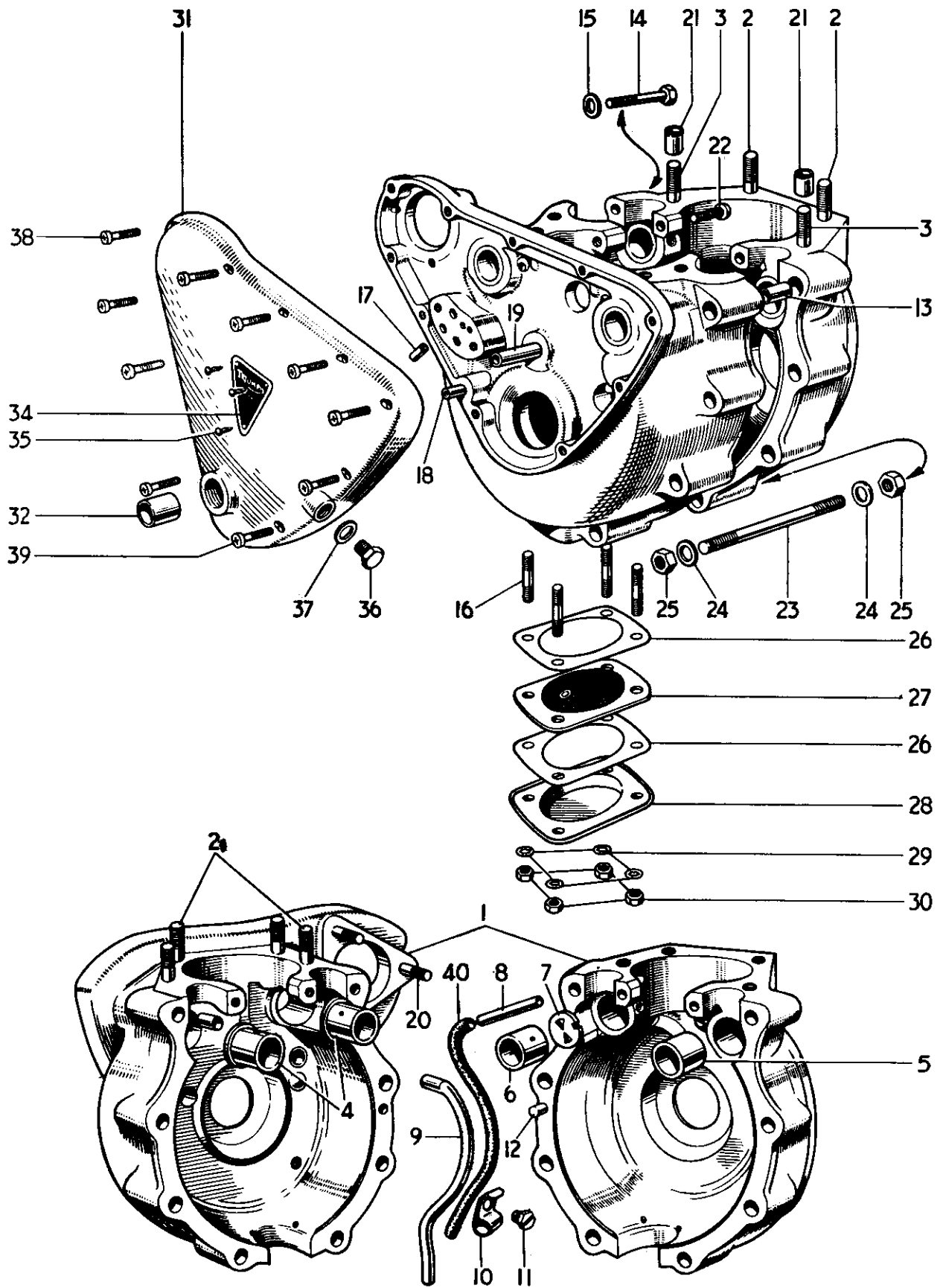
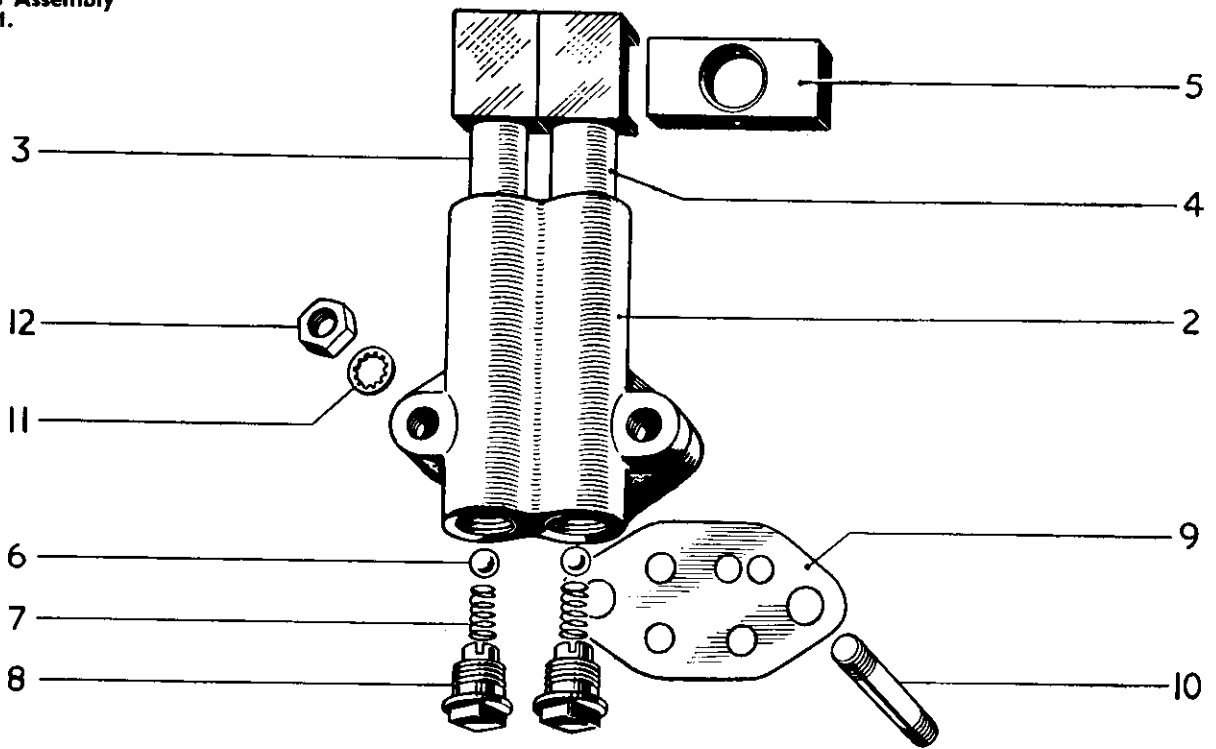

FIG. 2 CRANKCASE

Ref. No.	Part No.	DESCRIPTION	6T	T110	TR6	T120
CRANKCASE						
1	E2892/2314	CRANKCASE	1	1	1	1
2	E672	Cylinder base stud (1 $\frac{1}{8}$ " O.A.)	6	6	6	6
3	E3523	Cylinder base stud (1 $\frac{1}{8}$ " O.A.)	2	2	2	2
4	E1479	Camshaft bush	2	2	2	2
5	E1516	Camshaft bush	1	1	1	1
6	E2260	Camshaft breather bush	1	1	1	1
7	GS87	Breather disc	1	1	1	1
8	E2724	Breather pipe	1	1	1	1
9	E1508	Oil scavenge pipe	1	1	1	1
10	E1509	Scavenge pipe clip	1	1	1	1
11	E1645	Screw ($\frac{1}{4}$ " U.H.)	1	1	1	1
12	E1579	Crankcase joint dowel	1	1	1	1
13	E1534A	Crankcase joint hollow dowel	1	1	1	1
14	E1555	Top rear bolt (1 $\frac{1}{8}$ " U.H.)	1	1	1	1
15	S25-3	Plain washer	1	1	1	1
16	E1540	Oil filter stud ($\frac{3}{8}$ " O.A.)	4	4	4	4
17	E1532	Oil junction block dowel	1	1	1	1
18	E1535	Timing cover dowel	1	1	1	1
19	E375	Intermediate wheel spindle	1	1	1	1
20	E2022	Magneto stud (1 $\frac{5}{16}$ " O.A.)	3	3	3	3
21	E1534A	Cylinder base dowel	2	2	2	2
22	E1647	Crankcase joint screw	2	2	2	2
23	T456	Bottom front stud (3 $\frac{3}{4}$ " O.A.)	1	1	1	1
24	S25-3	Plain washer	2	2	2	2
25	S1-51	Nut	2	2	2	2
26	E487	Filter joint washer	2	2	2	2
27	E529	Crankcase oil filter	1	1	1	1
28	E486	Filter cover	1	1	1	1
29	E1612	Serrated washer	4	4	4	4
30	F879	Nut	4	4	4	4
31	E3110	TIMING COVER	1	1	1	1
32	E378	Crankshaft oil feed bush	1	1	1	1
33	E3585	Crankshaft oil feed bush (0-020 in. undersize)	A	A	A	A
34	E4016	Patent plate	1	1	1	1
35	D208-5	Patent plate rivet	3	3	3	3
36	E2615	Timing cover plug	1	1	1	1
37	E1335	Copper washer	1	1	1	1
38	E3437	Cover screw ($\frac{1}{8}$ in. U.H.)	7	7	7	7
39	E3439	Cover screw (1 $\frac{3}{8}$ " U.H.)	3	3	3	3
40	E3078	Breather extension rubber pipe	1	1	1	1

Oil Pump Assembly
Ref. No. 1.



Release Valve Assembly
Ref. No. 13.

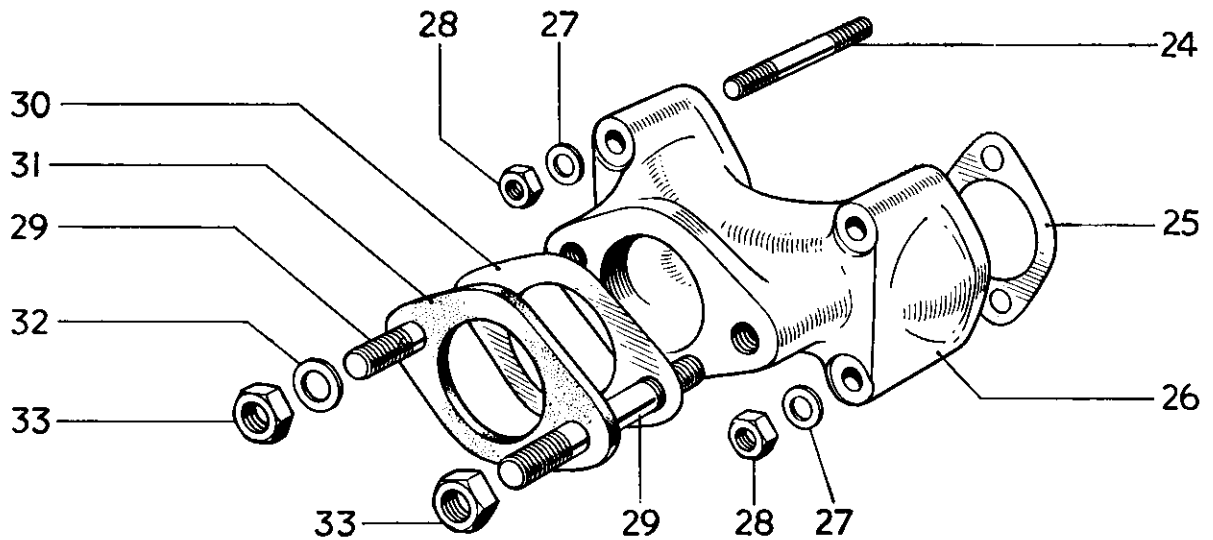
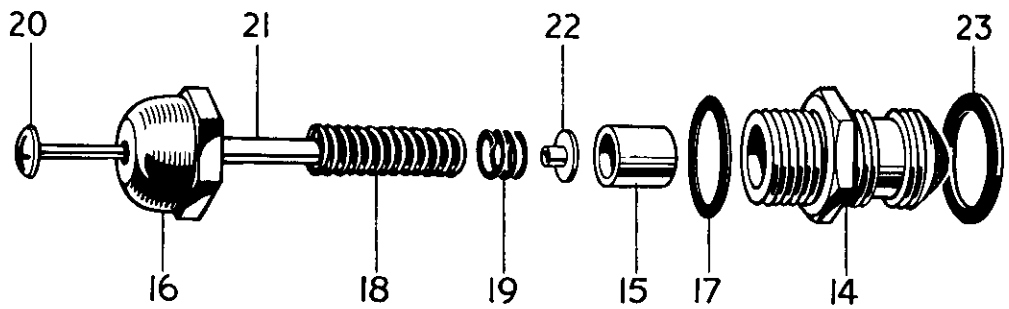

FIG. 3 OIL PUMP AND RELEASE VALVE AND MANIFOLD

OIL PUMP AND RELEASE VALVE AND MANIFOLD

										6T	T110	TR6	T120
1	E3072	OIL PUMP	1	1	1	1
2	GS35	Pump body	1	1	1	1
3	GS153	Feed plunger	1	1	1	1
4	E1476	Scavenge plunger	1	1	1	1
5	E495	Drive block	1	1	1	1
6	S70-7	Valve ball	2	2	2	2
7	E403	Valve spring	2	2	2	2
8	E2360	Screwed plug	2	2	2	2
9	E1537	Joint washer	1	1	1	1
10	E1536	Oil pump stud (1 $\frac{7}{16}$ " O.A.)	2	2	2	2
11	E1612	Serrated washer	2	2	2	2
12	F879	Nut	2	2	2	2
13	E2795	OIL RELEASE VALVE AND INDICATOR	1	1	1	1
14	E2794	Valve body	1	1	1	1
15	GS251	Piston	1	1	1	1
16	E2790	Cap	1	1	1	1
17	GS254	Fibre washer	1	1	1	1
18	E2788	Main spring	1	1	1	1
19	E2789	Auxiliary spring	1	1	1	1
20	E2791	Button and shaft	1	1	1	1
21	E2793	Sealing rubber	1	1	1	1
22	E2792	Shaft nut	1	1	1	1
23	E1670	Fibre washer	1	1	1	1
24	E2920	Stud (1 $\frac{33}{32}$ in. O.A.)	4	-	-	-
24	E2973	Stud (1 $\frac{15}{16}$ in. O.A.)	-	4	4	-
25	E3334	Joint washer	2	2	2	-
26	E3304	Inlet manifold	1	1	1	-
27	S25-13	Plain washer	4	4	4	-
28	W103	Nut	4	4	4	-
29	E1553	Stud (1 $\frac{3}{32}$ in. O.A.)	2	-	-	-
29	E2962	Stud (1 $\frac{7}{32}$ in. O.A.)	-	2	2	-
30	NA43A	Joint washer	-	1	1	-
31	E2968	Insulating block	-	1	1	-
32	S25-3	Plain washer	2	2	2	-
33	S1-51	Nut	2	2	2	-

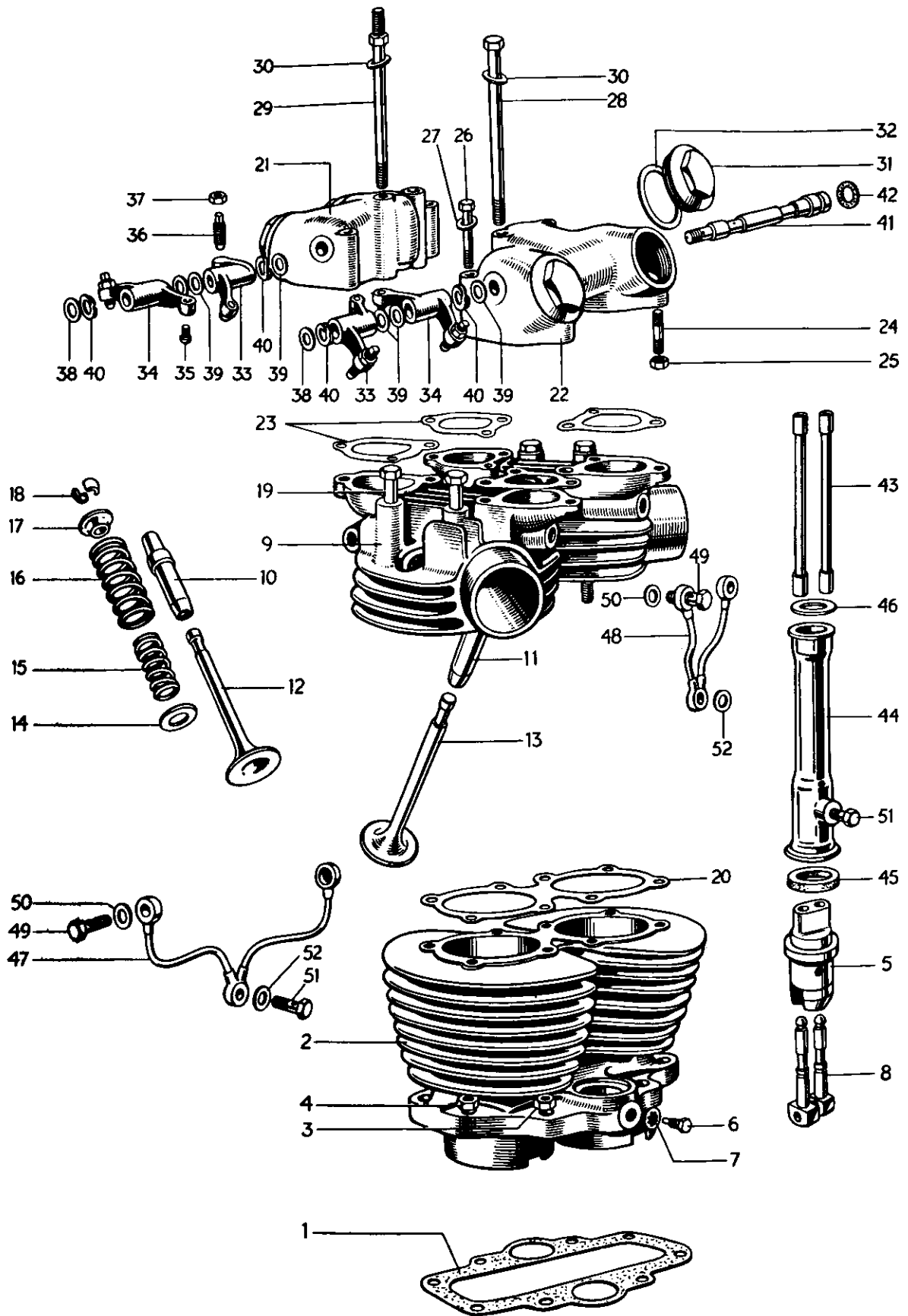

FIG. 4 CYLINDER BLOCK AND HEAD 6T

CYLINDER BLOCK AND HEAD, 6T

Ref. No.	Part No.	Description	Quantity
1	E2894	Cylinder base washer	1
2	E3332	Cylinder block	1
3	W76	Inner cylinder base nut	4
4	P0172A	Outer cylinder base nut	4
5	E1477	Tappet guide block	2
6	H200	Tappet block screw ($\frac{7}{16}$ " U.H.)	2
7	E1612	Serrated washer	2
8	E3059	Tappet	4
9	E3873	CYLINDER HEAD c/w GUIDES	1
10	E2899	Inlet valve guide	2
11	E2900	Exhaust valve guide	2
12	E2903	Inlet valve	2
13	E2904	Exhaust valve	2
14	E1544	Bottom cup	4
15	E1488	Inner valve spring	4
16	E1487	Outer valve spring	4
17	E1543	Top collar	4
18	WE259A	Split cotter	8
19	E327	Cylinder head bolt ($3\frac{3}{8}$ " U.H.)	4
20	E3614	Cylinder head gasket	1
21	E1461T	Inlet rocker box	1
22	E1462T	Exhaust rocker box	1
23	E1650	Joint washer	4
24	E1540	Rocker box stud ($\frac{3}{4}$ " O.A.)	4
25	F879	Rocker box nut	4
26	E1545	Rocker box bolt (2" U.H.)	4
27	S25-13	Plain washer	4
28	E1484	Cylinder head bolt ($5\frac{3}{8}$ " U.H.)	2
29	E1596	Cylinder head bolt (for torque stay)	2
30	GS308	Plain washer	4
31	E1564	Inspection cap	4
32	E1577	Joint washer	4
33	E1457	ROCKER (right exhaust, left inlet)	2
34	E1458	ROCKER (left exhaust, right inlet)	2
35	E1483	Rocker ball pin	4
36	E1513	Rocker adjusting pin	4
37	E470	Adjuster lock nut	4
38	E1330	Thrust washer, $\frac{3}{8}$ "	2
39	E1575	Thrust washer, $\frac{1}{2}$ "	6
40	E1574	Spring washer	4
41	E1512	Rocker spindle	2
42	E3253	Sealing rubber	2
43	E1693	Push rod	4
44	E1505	Cover tube	2
45	E1496	Bottom joint washer	2
46	E3547	Top joint washer	2
47	GS272	Rear drain pipe	1
48	GS273	Front drain pipe	1
49	E1601	Adaptor bolt	4
50	E1335	Copper washer	8
51	E984	Adaptor bolt	2
52	F1880	Copper washer	4

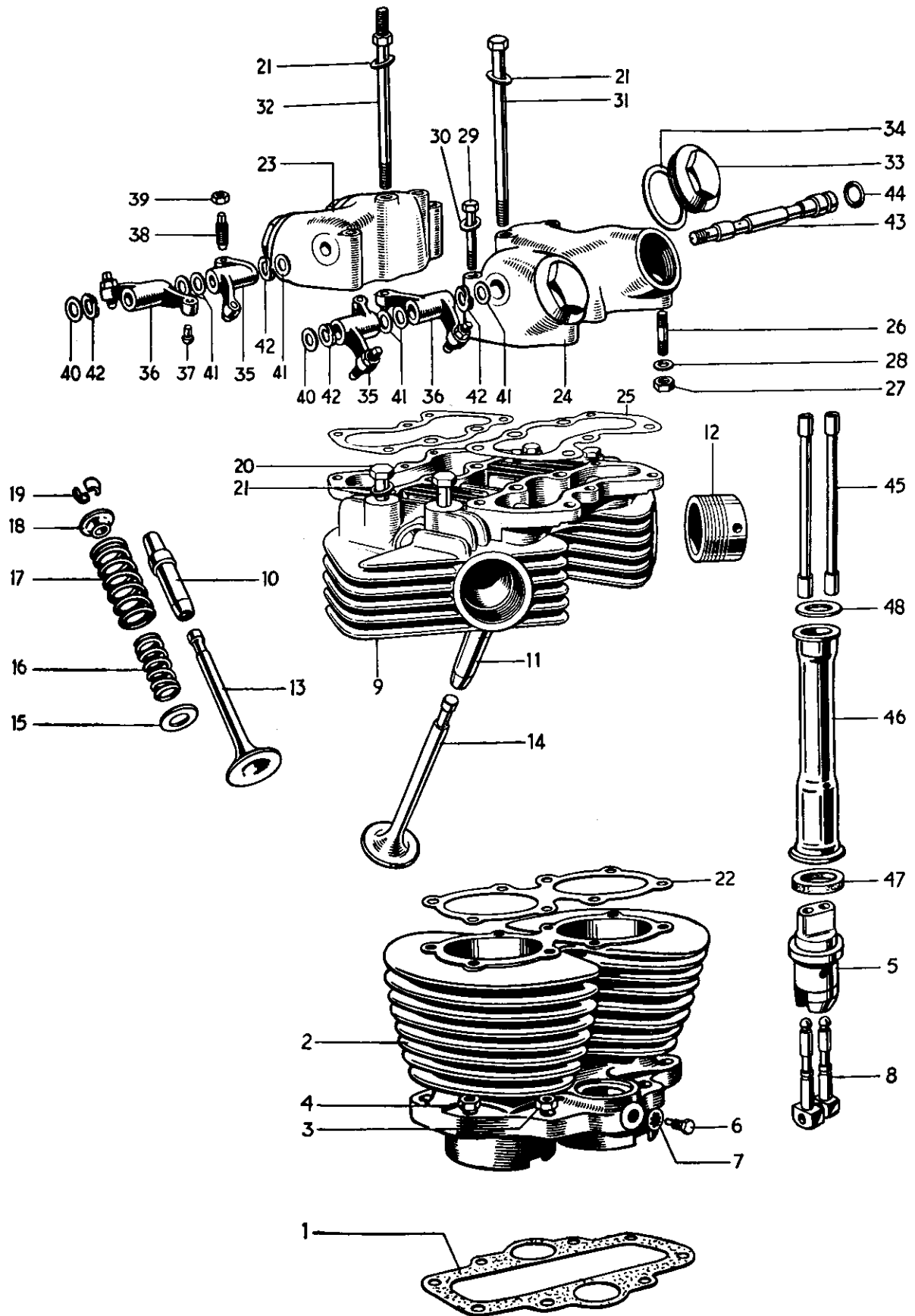

FIG. 5 CYLINDER BLOCK AND HEAD, T110 AND TR6

CYLINDER BLOCK AND HEAD, T110 & TR6

											T110	TR6
1	E2894	Cylinder base washer	1	1
2	E3332	Cylinder block	1	-
2	E3332/TR6	Cylinder block	-	1
3	W76	Inner cylinder base nut	4	4
4	PO172A	Outer cylinder base nut	4	4
5	E1477	Tappet guide block	2	2
6	H200	Tappet block screw ($\frac{7}{16}$ " U.H.)	2	2
7	E1612	Serrated washer	2	2
8	E3059	Tappet	4	4
9	E3924	CYLINDER HEAD c/w GUIDES	1	1
10	E2899	Inlet valve guide	2	2
11	E2900	Exhaust valve guide	2	2
12	E3583	Exhaust pipe adaptor	2	2
13	E3310	Inlet valve	2	2
14	E3927	Exhaust valve	2	2
15	E1544	Bottom cup	4	4
16	E1488	Inner valve spring	4	4
17	E1487	Outer valve spring	4	4
18	E1543	Top collar	4	4
19	WE259A	Split cotter	8	8
20	E2873	Cylinder head bolt ($3\frac{3}{4}$ " U.H.)	4	4
21	F2184	Plain washer	8	8
22	E3614	Cylinder head gasket	1	1
23	E3550	Inlet rocker box	1	1
24	E3551	Exhaust rocker box	1	1
25	E3552	Joint washer	2	2
26	E2980	Rocker box stud ($\frac{15}{16}$ " O.A.)	6	6
27	F879	Rocker box nut	6	6
28	E3302	Plain washer	6	6
29	E2982	Rocker box bolt ($2\frac{5}{32}$ " U.H.)	4	4
30	S25-13	Plain washer	4	4
31	E2874	Cylinder head bolt ($5\frac{1}{8}$ " U.H.)	2	2
32	E1596A	Cylinder head bolt (for torque stay)	2	2
33	E1564	Inspection cap	4	4
34	E1577	Joint washer	4	4
35	E1457	ROCKER (right exhaust, left inlet)	2	2
36	E1458	ROCKER (left exhaust, right inlet)	2	2
37	E1483	Rocker ball pin	4	4
38	E1513	Rocker adjusting pin	4	4
39	E470	Adjuster lock nut	4	4
40	E1330	Thrust washer, $\frac{3}{8}$ "	2	2
41	E1575	Thrust washer, $\frac{1}{2}$ "	6	6
42	E1574	Spring washer	4	4
43	E1512	Rocker spindle	2	2
44	E3253	Sealing rubber	2	2
45	E2620	Push rod	4	4
46	E3646	Cover tube	2	2
47	E1496	Bottom joint washer	2	2
48	E3547	Top joint washer	2	2

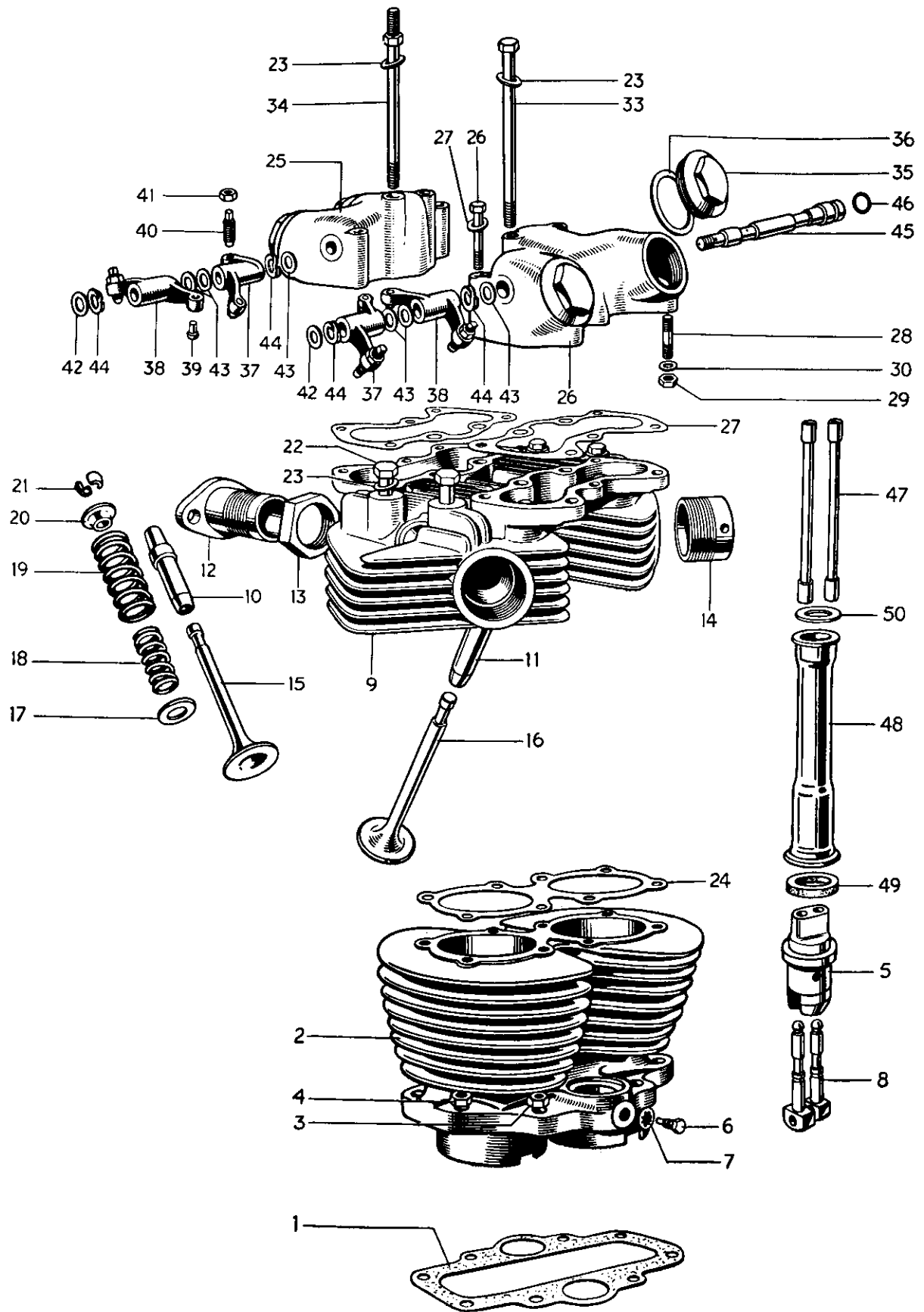

FIG. 6 CYLINDER BLOCK AND HEAD, T120

CYLINDER BLOCK AND HEAD, T120

Ref. No.	Part No.	DESCRIPTION	QUANTITY
			T120
1	E2894	Cylinder base washer	1
2	E3332	Cylinder block	1
3	W76	Inner cylinder base nut	4
4	PO172A	Outer cylinder base nut	4
5	E1477	Tappet guide block	2
6	H200	Tappet block screw ($\frac{7}{16}$ " U.H.)	2
7	E1612	Serrated washer	2
8	E3059	Tappet	4
9	E4019	CYLINDER HEAD c/w GUIDES	1
10	E3827	Inlet valve guide	2
11	E3828	Exhaust valve guide	2
12	E3940	Carburettor adaptor	2
13	E3847	Adaptor locking nut	2
14	E3583	Exhaust pipe adaptor	2
15	E3310	Inlet valve	2
16	E3927	Exhaust valve	2
17	E1544	Bottom cup	4
18	E3001	Inner valve spring	4
19	E3002	Outer valve spring	4
20	E1543	Top collar	4
21	WE259A	Split cotter	8
22	E2873	Cylinder head bolt ($3\frac{3}{8}$ " U.H.)	4
23	F2184	Plain Washer	8
24	E3614	Cylinder head gasket	1
25	E3550	Inlet rocker box	1
26	E3551	Exhaust rocker box	1
27	E3552	Joint washer	2
28	E2980	Rocker box stud ($1\frac{5}{8}$ " O.A.)	6
29	F879	Rocker box nut	6
30	E3302	Plain washer	6
31	E2982	Rocker box bolt ($2\frac{5}{32}$ " U.H.)	4
32	S25-13	Plain washer	4
33	E2874	Cylinder head bolt ($5\frac{1}{8}$ " U.H.)	2
34	E1596A	Cylinder head bolt (for torque stay)	2
35	E1564	Inspection cap	4
36	E1577	Joint washer	4
37	E1457	ROCKER (right exhaust, left inlet)	2
38	E1458	ROCKER (left exhaust, right inlet)	2
39	E1483	Rocker ball pin	4
40	E1513	Rocker adjusting pin	4
41	E470	Adjuster lock nut	4
42	E1330	Thrust washer, $\frac{3}{8}$ "	2
43	E1575	Thrust washer, $\frac{1}{2}$ "	6
44	E1574	Spring washer	4
45	E1512	Rocker spindle	2
46	E3253	Sealing rubber	2
47	E2620	Push rod	4
48	E3646	Cover tube	2
49	E1496	Bottom joint washer	2
50	E3547	Top joint washer	2

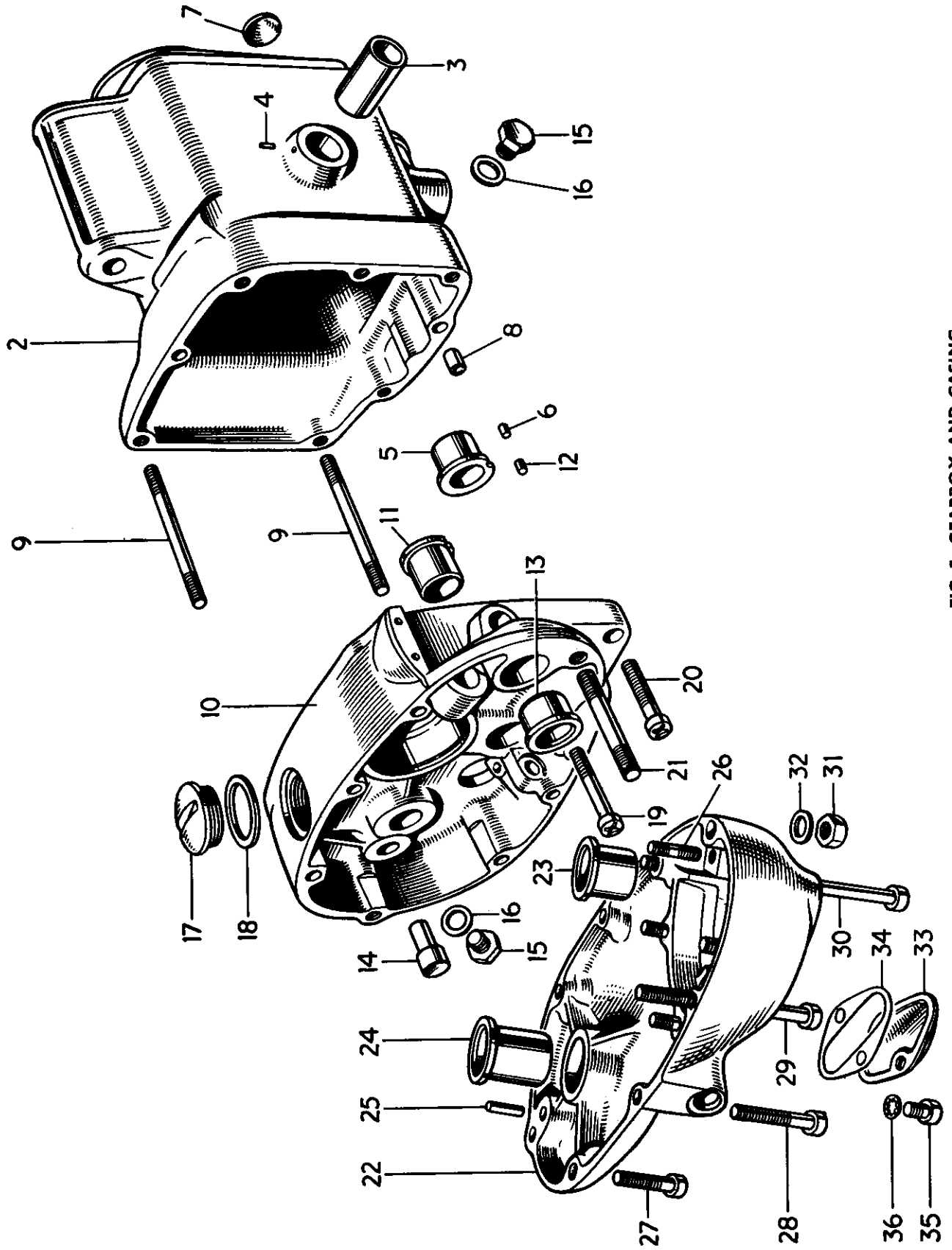

FIG. 7 GEARBOX AND CASING

Ref. No.	Part No.	DESCRIPTION	6T	T110	TR6	T120
GEARBOX AND CASING						
1	T1525	GEARBOX COMPLETE — STANDARD RATIO	1	1	-	-
1	T1528	GEARBOX COMPLETE — STANDARD RATIO	-	-	1	-
1	T1583	GEARBOX COMPLETE — STANDARD RATIO	-	-	-	1
1	T1526	GEARBOX COMPLETE — CLOSE RATIO	1	1	-	-
1	T1529	GEARBOX COMPLETE — CLOSE RATIO	-	-	1	-
1	T1584	GEARBOX COMPLETE — CLOSE RATIO	-	-	-	1
1	T1527	GEARBOX COMPLETE — WIDE RATIO	1	1	-	-
1	T1530	GEARBOX COMPLETE — WIDE RATIO	-	-	1	-
1	T1585	GEARBOX COMPLETE — WIDE RATIO	-	-	-	1
2	T1201	GEARBOX CASING	1	1	1	1
3	T341	Camplate bush	1	1	1	1
4	E3449	Peg	1	1	1	1
5	T1367	Layshaft bush	1	1	1	1
6	T912	Peg	1	1	1	1
7	T981	Blanking disc	1	1	1	1
8	T989	Dowel	2	2	2	2
9	E698	Cover securing stud (2 $\frac{7}{8}$ " O.A.)	2	2	2	2
10	T1562	GEARBOX INNER COVER	1	1	1	1
11	T1367	Layshaft bush	1	1	1	1
12	T912	Peg	1	1	1	1
13	T412	Gearchange spindle bush	1	1	1	1
14	T45	Kickstarter stop	1	1	1	1
15	S46-15	Drain and level plug	2	2	2	2
16	PT104B	Fibre washer	2	2	2	2
17	E732	Filler plug	1	1	1	1
18	NE507	Fibre washer	1	1	1	1
19	E3436	Inner cover screw (1 $\frac{1}{2}$ " U.H.)	1	1	1	1
20	E3437	Inner cover screw (1 $\frac{1}{8}$ " U.H.)	3	3	3	3
21	T323A	Cover securing stud (1 $\frac{1}{8}$ " O.A.)	1	1	1	1
22	T1534	GEARBOX OUTER COVER	1	1	1	1
23	T57	Gearchange spindle bush	1	1	1	1
24	T23	Kickstarter spindle bush	1	1	1	1
25	T47	Kickstarter spring anchor pin	1	1	1	1
26	T454	Guide plate stud (1 $\frac{1}{8}$ " O.A.)	4	4	4	4
27	E3437	Cover screw (1 $\frac{1}{8}$ " U.H.)	2	2	2	2
28	E3439	Cover screw (1 $\frac{3}{16}$ " U.H.)	1	1	1	1
29	E3438	Cover screw (2 $\frac{9}{16}$ " U.H.)	1	1	1	1
30	E3442	Cover screw (3" U.H.)	1	1	1	1
31	S1-51	Nut	3	3	3	3
32	S25-3	Plain washer	3	3	3	3
33	T1542	Cover plate	1	1	1	1
34	T1541	Joint washer	1	1	1	1
35	T1553	Cover screw (1 $\frac{3}{8}$ " U.H.)	2	2	2	2
36	E1612	Serrated washer	2	2	2	2

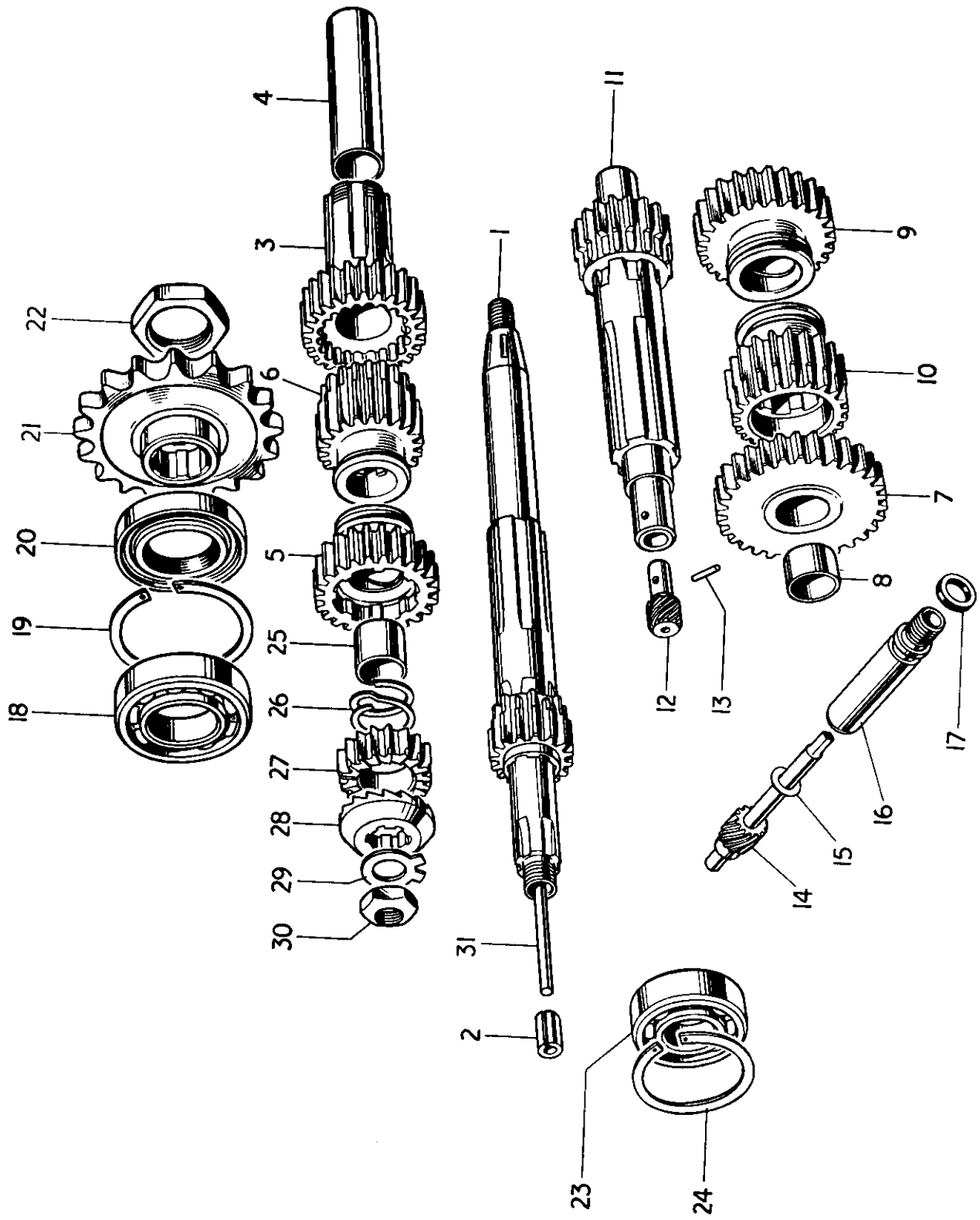

FIG. 8 GEARBOX SHAFTS AND GEARS

GEARBOX SHAFTS AND GEARS

						6T	T110	TR6	T120
1	T914	MAINSHAFT c/w LOW GEAR (16T)	1	1	1	1
2	PT108B	Clutch rod bush	1	1	1	1
3	T1382	MAINSHAFT HIGH GEAR (26T)	1	1	1	1
4	T1370	High gear bush	1	1	1	1
5	T917	Mainshaft third gear (24T)	1	1	1	1
6	T916	Mainshaft second gear (20T)	1	1	1	1
7	T926	LAYSHAFT LOW GEAR (30T)	1	1	1	1
8	T928	Low gear bush	1	1	1	1
9	T1065	Layshaft second gear (26T)	1	1	1	1
10	T930	Layshaft third gear (22T)	1	1	1	1
11	T1063	LAYSHAFT COMPLETE (20T)	1	1	1	1
12	T924	Speedometer drive pinion (10T)	1	1	1	1
13	T925	Securing pin	1	1	1	1
14	T934	Speedometer driven gear (16T)	1	1	1	1
15	T825	Thrust washer	1	1	1	1
16	T933	Speedometer drive bush	1	1	1	1
17	T948	Rubber sealing ring	1	1	1	1
18	T448	High gear bearing	1	1	1	1
19	E489	Circlip	1	1	1	1
20	T946	High gear oil seal	1	1	1	1
21	T471A	Gearbox sprocket (18T)	1	1	1	1
22	T440	Gearbox sprocket nut	1	1	1	1
23	S35-7	Mainshaft bearing	1	1	1	1
24	T280	Circlip	1	1	1	1
25	T1338	Kickstarter pinion sleeve	1	1	1	1
26	T1250	Kickstarter pinion spring	1	1	1	1
27	T730	Kickstarter pinion	1	1	1	1
28	T731	Kickstarter ratchet	1	1	1	1
29	T732	Tab washer	1	1	1	1
30	NT297	Mainshaft nut	1	1	1	1
31	T1552	Clutch operating rod	1	1	1	1

To convert to Wide Ratio Gears use Gear Set C.P.94

3	T1384	MAINSHAFT HIGH GEAR (28T)	1	1	1	1
4	T1370	High gear bush	1	1	1	1
6	T968	Mainshaft second gear (19T)	1	1	1	1
9	T974	Layshaft second gear (27T)	1	1	1	1
11	T971	LAYSHAFT COMPLETE (18T)	1	1	1	1
12	T973	Speedometer drive pinion (8T)	1	1	1	1
13	T925	Securing pin	1	1	1	1
14	T975	Speedometer driven gear (15T)	1	1	1	1

To Convert to Close Ratio Gears use Gear Set C.P.95

1	T1177	MAINSHAFT c/w LOW GEAR (18T)	1	1	1	1
2	PT108B	Clutch rod bush	1	1	1	1
3	T1383	MAINSHAFT HIGH GEAR (24T)	1	1	1	1
4	T1370	High gear bush	1	1	1	1
5	T1179	Mainshaft third gear (23T)	1	1	1	1
6	T955	Mainshaft second gear (21T)	1	1	1	1
7	T961	LAYSHAFT LOW GEAR (28T)	1	1	1	1
8	T928	Low gear bush	1	1	1	1
9	T963	Layshaft second gear (25T)	1	1	1	1
10	T964	Layshaft third gear (23T)	1	1	1	1
11	T959	Layshaft c/w high gear (22T)	1	1	1	1

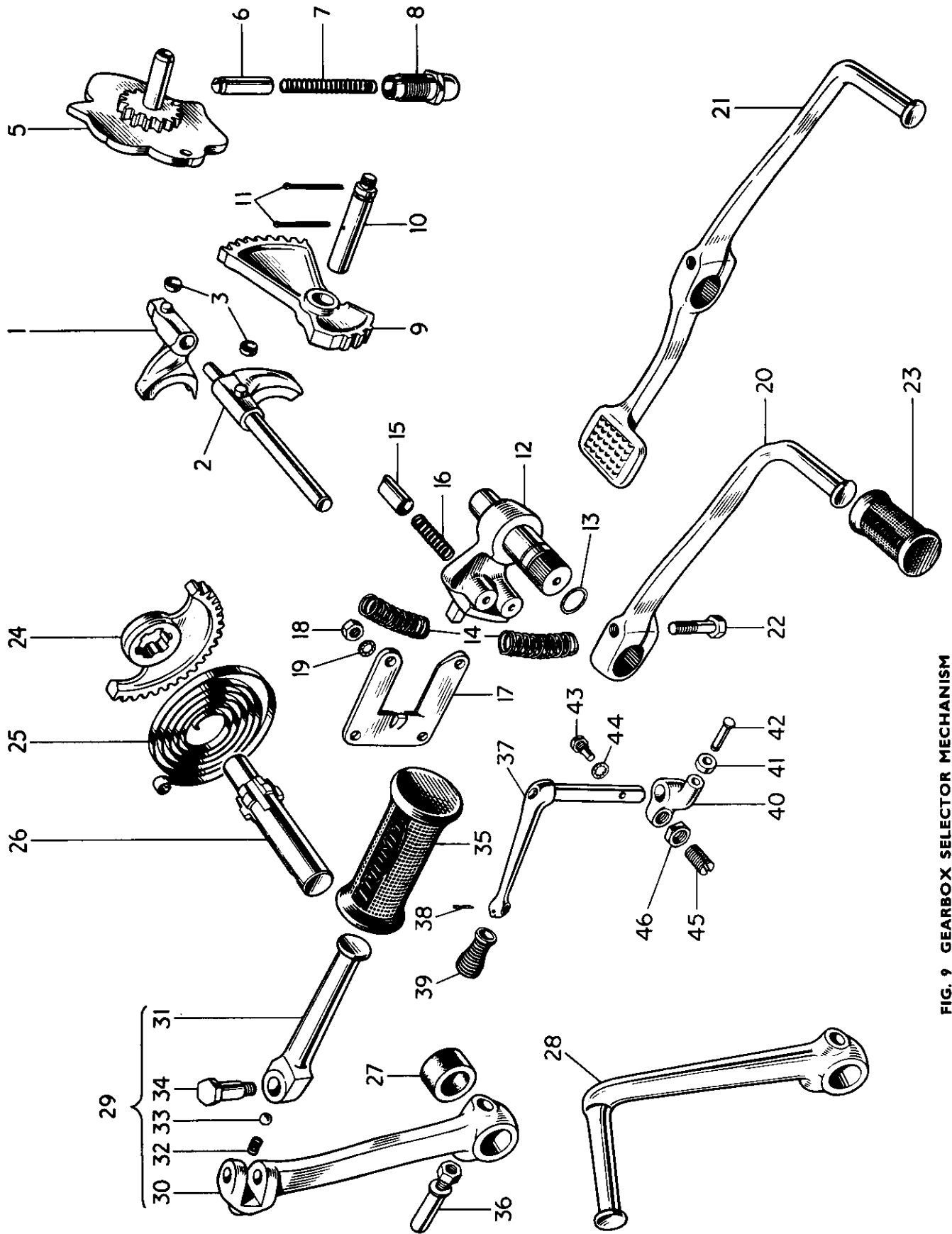

FIG. 9 GEARBOX SELECTOR MECHANISM

GEARBOX SELECTOR MECHANISM

								6T	T110	TR6	T120
1	T260B	Mainshaft selector fork	1	1	1	1
2	T913	Layshaft selector fork	1	1	1	1
3	NT261	Selector fork roller	2	2	2	2
4	T291	Selector fork rod	1	1	1	1
5	T500	Gear selector camplate	1	1	1	1
6	T44	Camplate index plunger	1	1	1	1
7	T373	Index plunger spring	1	1	1	-
7	T1604	Index plunger spring	-	-	-	1
8	T372	Index plunger holder	1	1	1	1
9	T397	Camplate operating quadrant	1	1	1	1
10	T399	Quadrant spindle	1	1	1	1
11	$\frac{5}{16}'' \times 1\frac{3}{8}''$	Split pin	2	2	2	2
12	T408/1540	Gearchange quadrant	1	1	1	1
13	E3309	Rubber "O" ring	1	1	1	1
14	T404	Quadrant return spring	2	2	2	2
15	T406	Gearchange quadrant plunger	2	2	2	2
16	T405	Plunger spring	2	2	2	2
17	T407	Guide plate	1	1	1	1
18	F879	Nut	4	4	4	4
19	E1612	Serrated washer	4	4	4	4
20	T1194	Gearchange pedal	1	1	1	1
21	T1564	Heel-and-toe gearchange pedal	A	A	A	A
22	W932	Pedal bolt (1" U.H.)	1	1	1	1
23	T449	Pedal rubber	1	1	1	1
24	T25A	Kickstarter quadrant	1	1	1	1
25	T31	Kickstarter return spring	1	1	1	1
26	T24A	Kickstarter axle	1	1	1	1
27	T1512	Rubber sleeve	1	1	1	1
28	T451	Kickstarter crank	1	1	-	1
29	T1270	FOLDING KICKSTARTER	-	-	1	-
30	T1271	Kickstarter lever	-	-	1	-
31	T1272	Kickstarter pedal	-	-	1	-
32	T1167	Pedal locating spring	-	-	1	-
33	S70-3	Pedal locating ball...	-	-	1	-
34	T1273	Pedal bolt (1-155" U.H.)	-	-	1	-
35	F1814	Pedal rubber	1	1	1	1
36	T1222	Cotter pin c/w nut and washer	1	1	1	1
37	T1539	Clutch operating lever	1	1	1	1
38	$\frac{1}{16}'' \times \frac{1}{2}''$	Split pin	1	1	1	1
39	T495	Rubber cap	1	1	1	1
40	T402	Clutch operating arm	-	-	-	1
40	T1536	CLUTCH OPERATING ARM	1	1	1	-
41	T1538	Roller	1	1	1	-
42	E3412	Roller fixing pin	1	1	1	-
43	T1554	Screwed peg	1	1	1	1
44	E1612	Serrated washer	1	1	1	1
45	T413	Clutch rod adjuster pin	1	1	1	1
46	T453	Adjuster pin nut	1	1	1	1

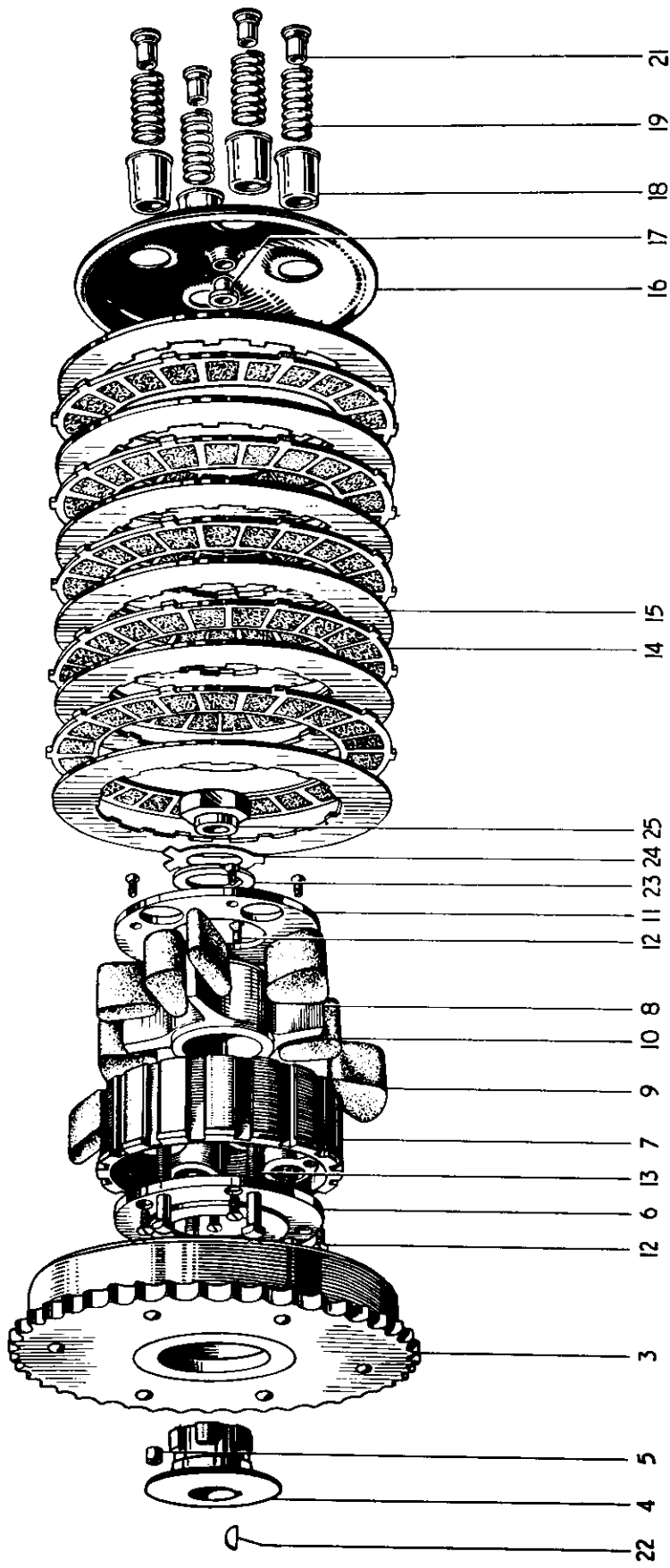

FIG. 10 CLUTCH

Ref. No.	Part No.	DESCRIPTION	6T	T110	TR6	T120
CLUTCH						
1	T1548	CLUTCH COMPLETE	1	1	1	-
2	T1586	CLUTCH COMPLETE	-	-	-	1
3	T1549	Sprocket and housing	1	1	1	1
4	T418	Hub	1	1	1	1
5	T394	Rollers	20	20	20	20
6	T1039	Inner plate	1	1	1	1
7	T1038	Centre (Shock absorber body)	1	1	1	1
8	T1041	Shock absorber spider	1	1	1	1
9	T1472	Drive rubber (large)	4	4	4	4
10	T1473	Rebound rubber (small)	4	4	4	4
11	T1044	Outer plate	1	1	1	1
12	T1040	Countersunk screw (0.417" U.H.)	8	8	8	8
13	T423A	Screwed pin (1/8" U.H.)	4	4	4	4
14	T1362	Driving plate (bonded)	5	5	5	5
15	T1363	Driven plate (plain)	6	6	6	6
16	T986	PRESSURE PLATE	1	1	1	1
17	T422	Thrust button	1	1	1	1
18	T998	Spring cup	4	4	4	4
19	T999	Spring	4	4	4	-
20	T1560	Spring (strong)	A	A	A	4
21	T427	Brass nut	4	4	4	4
22	S66-1	Key	1	1	1	1
23	T1045	Cupped washer	1	1	1	1
24	T1046	Tab washer	1	1	1	1
25	T1047	Clutch securing nut	1	1	1	1

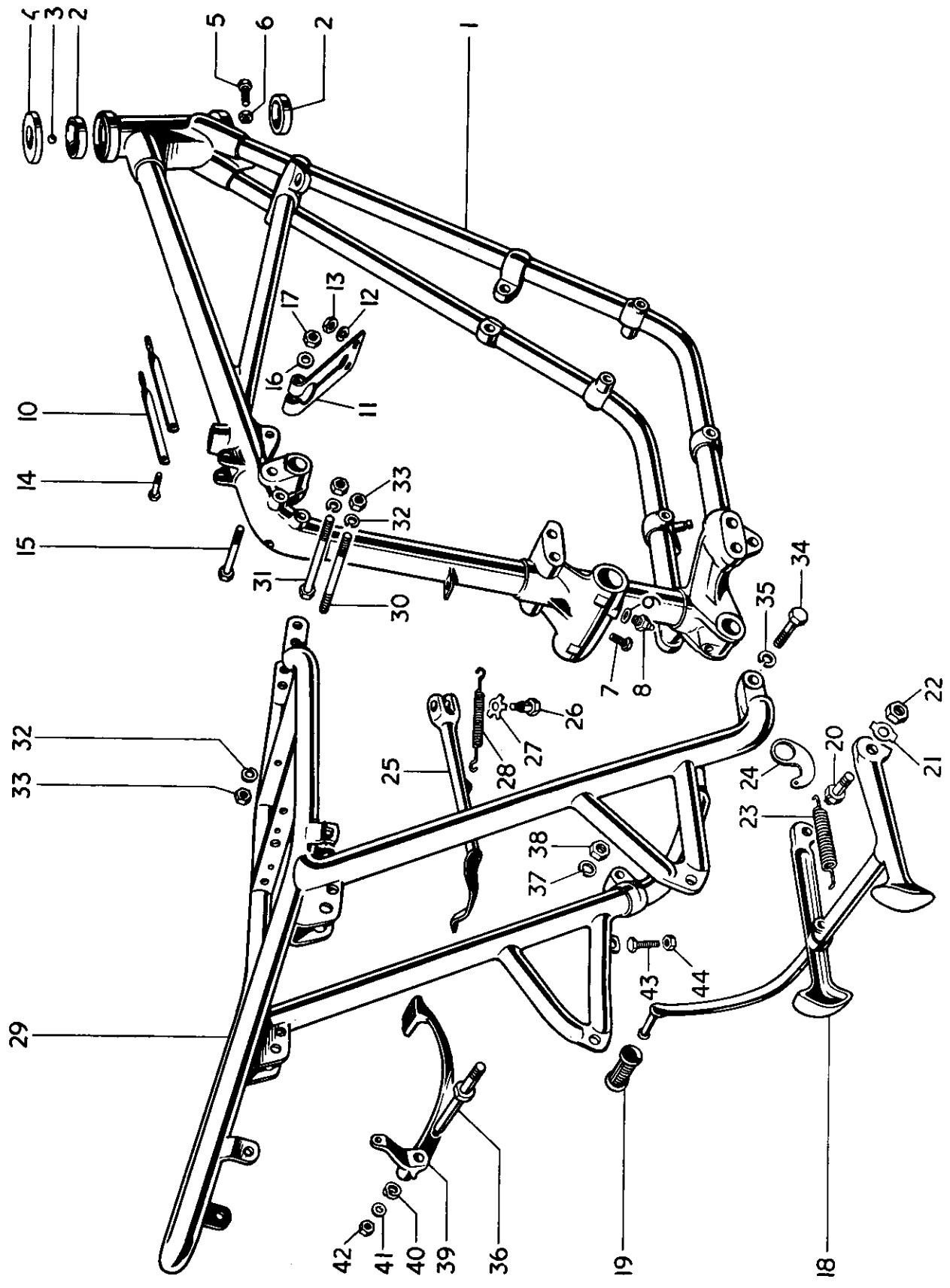

FIG. 11 FRAME

Ref. No.	Part No.	DESCRIPTION	QUANTITY			
FRAME						
			6T	T110	TR6	T120
1	F4608	Front frame	1	1	1	1
2	H111	Steering race cup	2	2	2	2
3	S70-3	Steel ball ($\frac{1}{2}$ " diam.)	40	40	40	40
4	H1018	Top cone and dust cover	1	1	1	1
5	DS55	Steering stop bolt ($\frac{13}{16}$ " U.H.)	2	2	2	2
6	T224	Nut	2	2	2	2
7	DS57	Plug screw ($\frac{7}{16}$ " U.H.)	-	-	1	1
8	NW100	Grease nipple	1	1	1	1
9	WE170	Fibre washer	1	1	1	1
10	E4115	Engine torque stay	2	2	2	-
11	E4164	Engine torque stay	-	-	-	1
12	S26-1	Spring washer	2	2	2	2
13	S1-52	Nut	2	2	2	2
14	F2603	Bolt ($\frac{13}{16}$ " U.H.)	1	1	1	-
15	E3181	Bolt ($2\frac{1}{4}$ " U.H.)	-	-	-	1
16	S26-3	Spring washer	1	1	1	1
17	E1310	Nut	1	1	1	-
17	S1-51	Nut	-	-	-	1
18	F4304	Centre stand	1	1	-	-
18	F4763	Centre stand	-	-	1	1
19	T449	Pedal rubber	1	1	1	1
20	F3619	Pivot bolt ($1\frac{3}{16}$ " U.H.)	2	2	2	2
21	F4484	Tab washer	2	2	2	2
22	F2725	Nut	2	2	2	2
23	F4671	Return spring	1	1	1	1
24	F4670	Return spring link	1	1	1	1
25	F4712	PROP STAND COMPLETE	1	1	-	-
25	F3723	PROP STAND COMPLETE	-	-	1	1
26	F3097	Pivot bolt	1	1	1	1
27	F3096	Tab washer	1	1	1	1
28	F2610	Return spring	1	1	1	1
29	F4609	Rear frame	1	1	-	-
29	F4684	Rear frame	-	-	1	1
30	F2842	Stud ($3\frac{7}{8}$ " O.A.)	2	2	1	1
31	F4685	Bolt ($3\frac{11}{16}$ " U.H.)	-	-	1	1
32	S26-1	Spring washer	4	4	3	3
33	S1-52	Nut	4	4	3	3
34	F3780	Bolt ($1\frac{1}{8}$ " U.H.)	2	2	2	2
35	PCW73A	Spring washer	2	2	2	2
36	F4650	Brake pedal spindle	1	1	1	1
37	SCZ45	Spring washer	1	1	1	1
38	DS48	Nut	1	1	1	1
39	F4647	Brake pedal	1	1	1	1
40	S26-16	Spring washer	1	1	1	1
41	S25-2	Plain washer	1	1	1	1
42	S1-52	Nut	1	1	1	1
43	F1149	Pedal stop screw ($\frac{13}{16}$ " U.H.)	1	1	1	1
44	F879	Nut	1	1	1	1

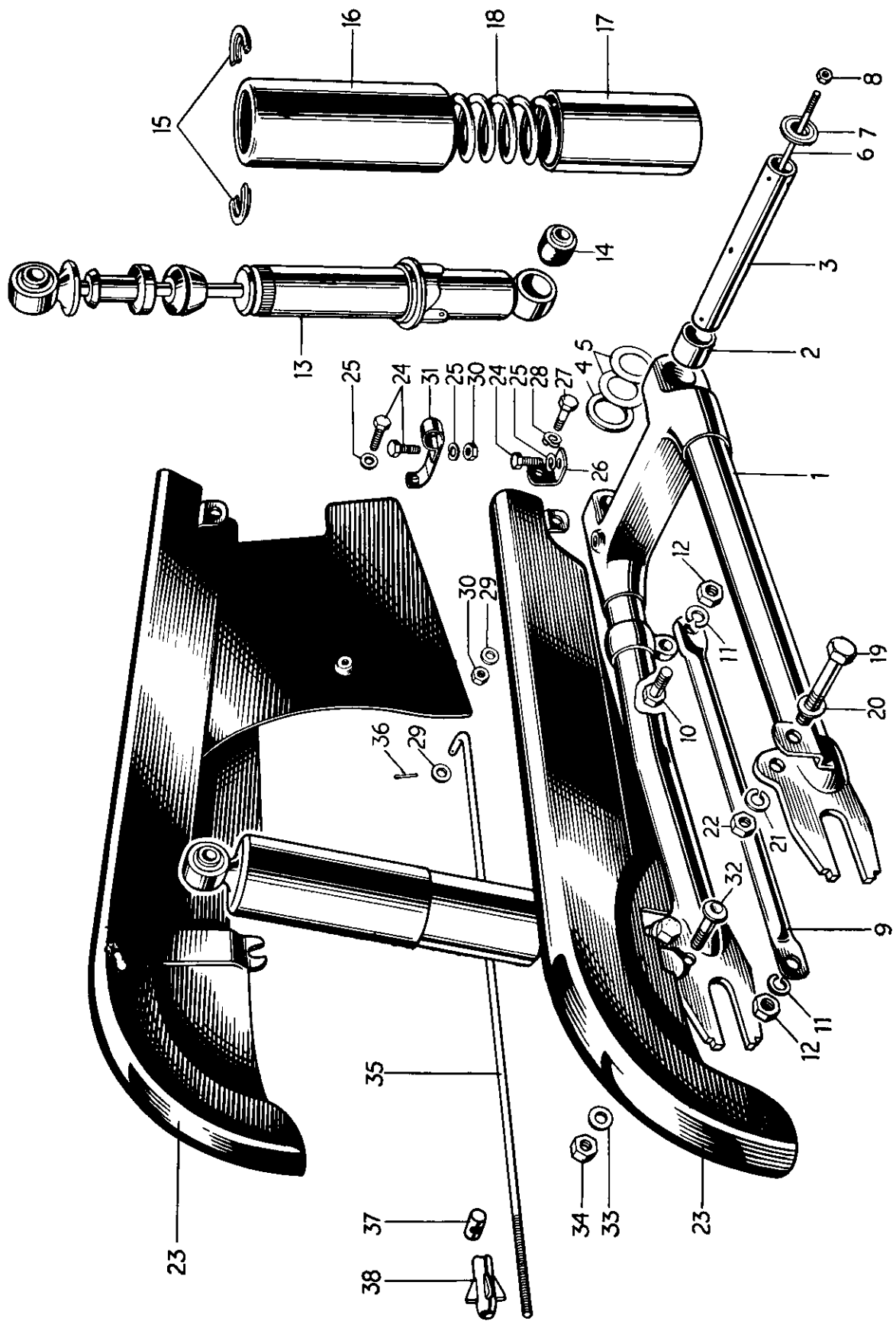

FIG. 12 SWINGING FORK AND SUSPENSION UNITS

SWINGING FORK AND SUSPENSION UNITS

			6T	T110	TR6	T120
1	F4131	SWINGING FORK	1	1	1	1
2	F3690	Pivot bush	2	2	2	2
3	F3564	Spindle	1	1	1	1
4	F3574	Spacing washer	1	1	1	1
5	F3683	0-003" Shim	}	as required		
5	F3684	0-005" Shim				
6	F3797	Retainer rod	1	1	1	1
7	F3798	Cap	2	2	2	2
8	F3799	Nut	1	1	1	1
9	F3774	Brake torque stay	1	1	1	1
10	F3780	Bolt (1 1/8" U.H.)	1	1	1	1
11	PCW73A	Spring washer	2	2	2	2
12	DS47	Nut	2	2	2	2
13	SB4/259	SOLO SUSPENSION UNIT	2	2	-	-
13	SB4/275	SIDECAR SUSPENSION UNIT	2	2	2	2
13	64054164	SOLO SUSPENSION UNIT	-	-	2	2
14	9054/316A	Bonded bush	4	4	4	4
15	9054/171	Spring retainer	4	4	4	4
16	9054/151	Outer dirt shield	2	2	2	2
17	9054/47	Inner dirt shield	2	2	2	2
18	SA193/57	Spring 150 lbs. (sidecar) Blue/Red	A	A	A	A
18	9054/63	Spring 130 lbs. Red/Yellow	A	A	A	A
18	9054/70	Spring 110 lbs. Purple/Blue	A	A	A	A
18	9054/280	Spring 100 lbs. Green/Green	2	2	2	2
18	9054/69	Spring 90 lbs. (road racing) Yellow/White	A	A	A	A
19	E2113	Unit fixing bolt (1 5/8" U.H.)	4	4	4	4
20	S25-2	Plain washer	2	2	2	2
21	S26-1	Spring washer	4	4	4	4
22	PO172A	Nut	4	4	4	4
23	F4130	Chainguard	1	1	-	1
23	F4138	Chainguard	-	-	1	-
24	DS57	Bolt	1	1	3	1
25	S26-2	Spring washer	1	1	3	1
26	F4134	Front bracket	1	1	1	1
27	F4135	Pivot bolt	1	1	1	1
28	F2277	Spring washer	1	1	1	1
29	S25-13	Plain washer	2	2	2	2
30	F879	Nut	1	1	3	1
31	F4140	Centre bracket	-	-	1	-
32	F4136	Stepped bolt	1	1	1	1
33	S25-3	Plain washer	1	1	1	1
34	S1-51	Nut	1	1	1	1
35	F3597	Brake operating rod	1	1	1	1
36	1/8" x 3/8"	Split pin	1	1	1	1
37	W11	Pivot pin	1	1	1	1
38	F4585	Adjuster nut	1	1	1	1

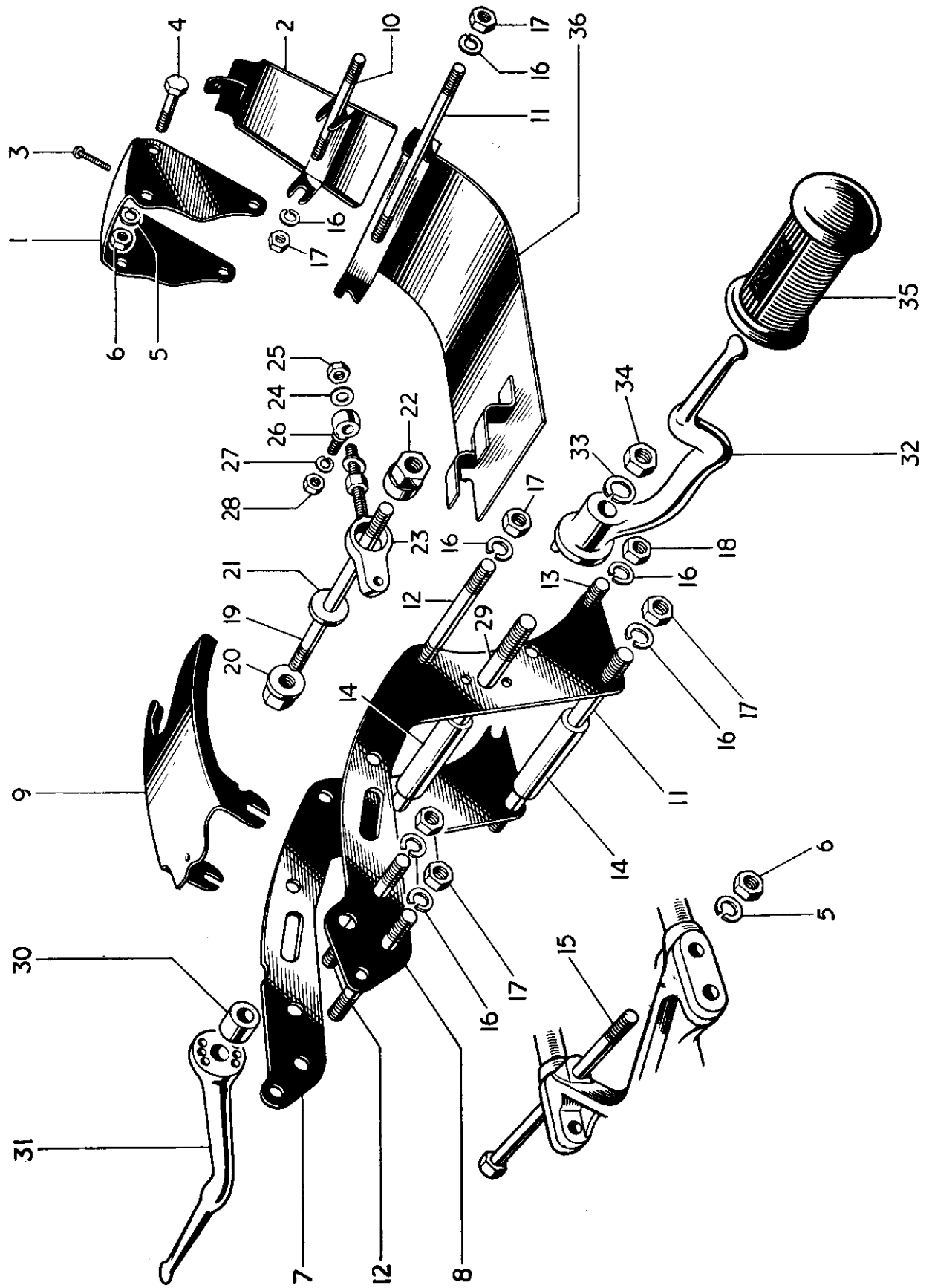

FIG. 13 ENGINE AND GEARBOX FITTINGS

Ref. No.	Part No.	DESCRIPTION	QUANTITY			
ENGINE AND GEARBOX FITTINGS						
			6T	T110	TR6	T120
1	F4651	Front engine plate	1	1	1	1
2	F4719	Engine plate cover	1	1	-	-
3	F4715	Screw	1	1	-	-
4	F3780	Bolt (1 $\frac{1}{8}$ " U.H.)	2	2	2	2
5	PCW73A	Spring washer	3	3	3	3
6	DS47	Nut	3	3	3	3
7	F3760	Left rear engine plate	1	1	1	1
8	F3451	Right rear engine plate	1	1	1	1
9	F3571	Cover plate	1	1	1	1
10	F1711	Stud (4 $\frac{1}{8}$ " O.A.)	2	2	2	2
11	F4682	Stud (7 $\frac{3}{32}$ " O.A.)	2	2	2	2
12	F839	Stud (4 $\frac{7}{16}$ " O.A.)	4	4	4	4
13	F3665	Stud (4 $\frac{1}{4}$ " O.A.)	1	1	1	1
14	F862	Distance tube	2	2	2	2
15	F4681	Gearbox pivot bolt (8 $\frac{1}{4}$ " U.H.)	1	1	1	1
16	S26-1	Spring washer	18	18	18	18
17	PO172A	Nut	16	16	16	16
18	S1-52	Nut	2	2	2	2
19	F3769	Gearbox top stud (4 $\frac{1}{8}$ " O.A.)	1	1	1	1
20	F3771	Flanged nut	1	1	1	1
21	F3770	Clamping washer	1	1	1	1
22	F3772	Sleeve nut	1	1	1	1
23	F4646	Gearbox adjuster eyebolt	1	1	1	1
24	GS203	Plain washer	2	2	2	2
25	E1310	Nut	2	2	2	2
26	F4669	Abutment pin	1	1	1	1
27	S26-3	Spring washer	1	1	1	1
28	S1-51	Nut	1	1	1	1
29	F3592	Footrest hanger rod	1	1	1	1
30	T87	Left distance piece	1	1	1	1
31	F987	Left footrest	1	1	1	1
32	F3593	Right footrest	1	1	1	1
33	SCZ45	Spring washer	1	1	1	1
34	DS48	Nut	2	2	2	2
35	NF704	Pedal rubber	2	2	2	2
36	F4695	Crankcase undershield	A	A	1	A

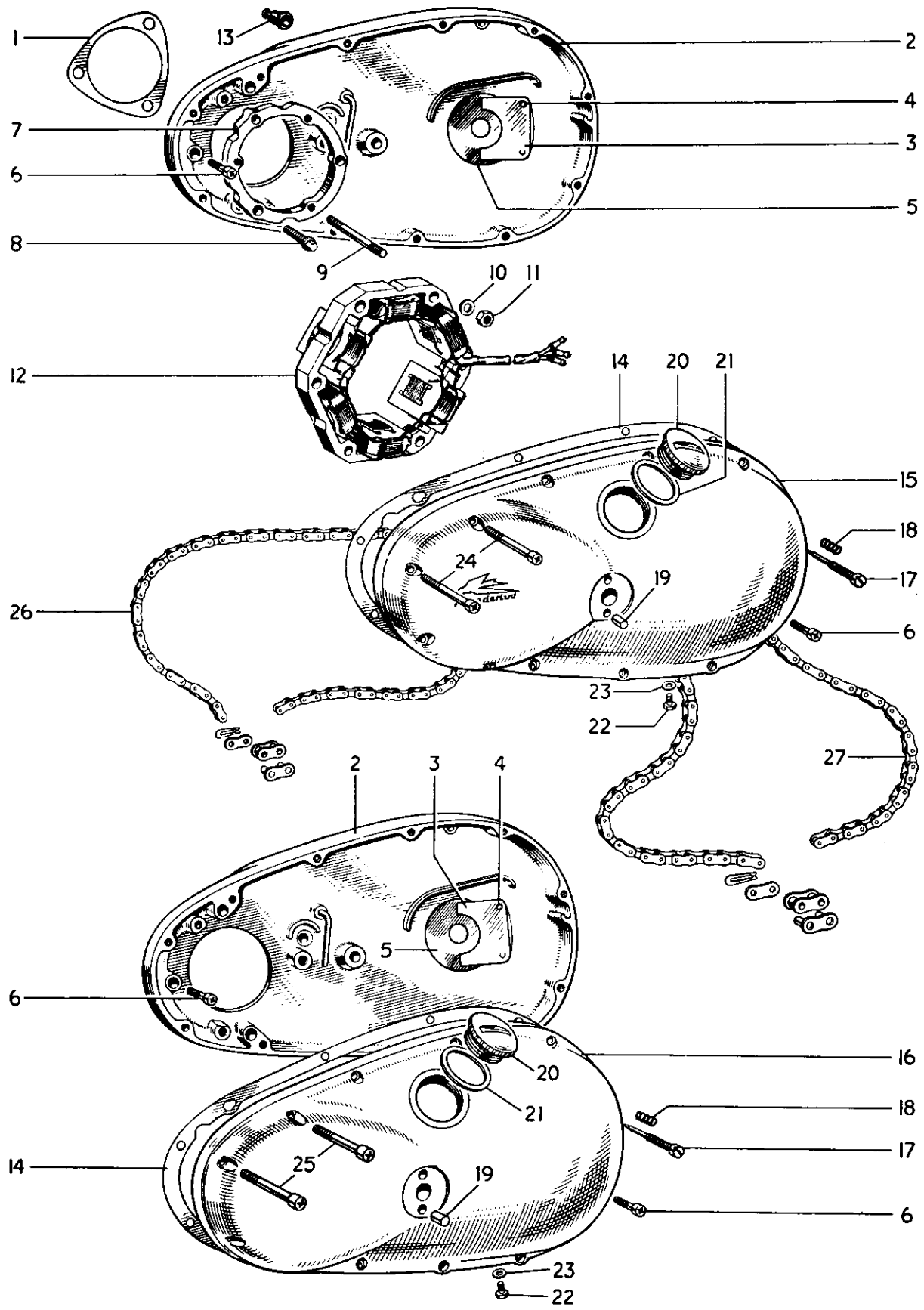

FIG. 14 CHAINCASE AND ALTERNATOR

CHAINCASE AND ALTERNATOR

			6T	T110	TR6	T120
1	T1477	Joint washer	1	1	1	1
2	T1603	INNER CHAINCASE	1	1	-	-
2	T1600	INNER CHAINCASE	-	-	1	1
3	T91	Retainer plate	1	1	1	1
4	T177A	Rivet	1	1	1	1
5	T1381	Oil sealing plate	1	1	1	1
6	E3437	Screw ($\frac{15}{16}$ " U.H.)	11	11	11	11
7	E3978	Adaptor ring	1	1	1	1
8	E3979	Flanged head bolt ($1\frac{3}{16}$ " U.H.)	3	3	3	3
9	E3980	Stud ($1\frac{3}{4}$ " O.A.)	3	-	-	-
9	E4123	Stud ($1\frac{13}{16}$ " O.A.)	-	3	3	3
10	S25-3	Plain washer	3	3	3	3
11	E1310	Nut	3	3	3	3
12	469427	Stator	1	-	-	-
12	47134	Stator	-	1	1	1
13	T1059	Cable grommet	1	1	1	1
14	T1226	Joint washer	1	1	1	1
15	T1237	Outer chaincase	1	-	-	-
16	T1601	Outer chaincase	-	1	1	1
17	T496	Oil restrictor screw	1	1	1	1
18	T497	Spring	1	1	1	1
19	NT316	Footrest dowel	4	4	4	4
20	NT367	Filler plug	1	1	1	1
21	NT376	Leather washer	1	1	1	1
22	PCE102F	Drain plug	1	1	1	1
23	WE170	Fibre washer	1	1	1	1
24	E3449	Screw ($2\frac{1}{8}$ " U.H.)	4	-	-	-
25	E3440	Screw ($1\frac{11}{16}$ " U.H.)	-	4	4	4
26	D301	Primary chain ($\frac{1}{2}$ " \times $\frac{5}{16}$ " \times 70L)	1	1	1	1
27	D438	Rear chain ($\frac{5}{8}$ " \times $\frac{3}{8}$ " \times 99L)	1	1	1	1

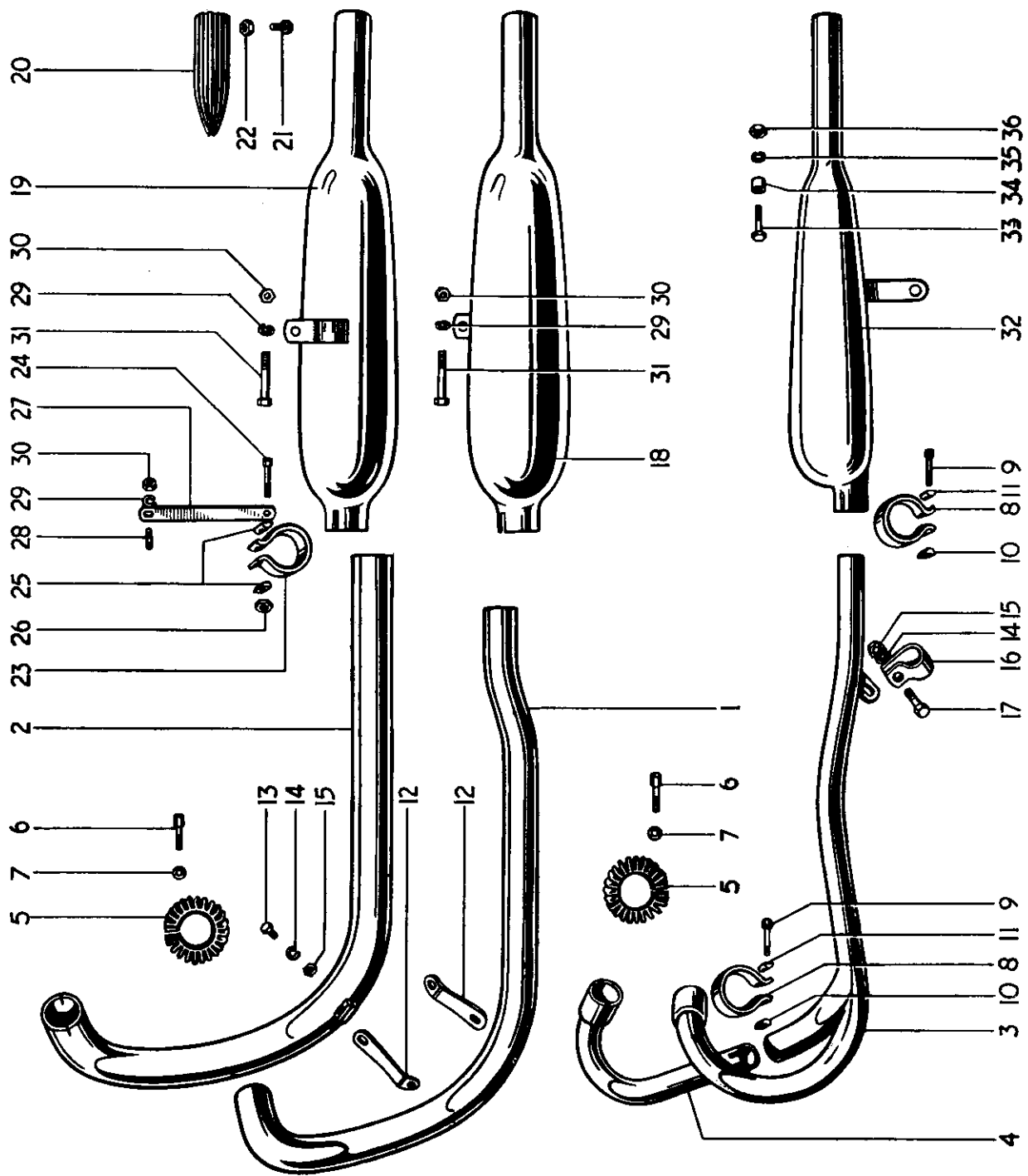

FIG. 15 EXHAUST PIPES AND SILENCERS

EXHAUST PIPES AND SILENCERS

			6T	T110	TR6	T120
1	E3426	Left exhaust pipe	1	-	-	-
1	E4133	Left exhaust pipe	-	1	-	1
2	E3350	Right exhaust pipe	1	-	-	-
2	E3632	Right exhaust pipe	-	1	-	1
3	E4125	Left exhaust pipe	-	-	1	-
4	E4130	Right exhaust pipe	-	-	1	-
5	E1269	Finned clip	2	2	2	2
6	E409	Clip bolt (1 $\frac{3}{16}$ " H.H.)	2	2	2	2
7	E410A	Spherical washer	2	2	2	2
8	E3469	Extension pipe and silencer clip	-	-	2	-
9	TE164E	Clip bolt (1 $\frac{3}{16}$ " U.H.)	-	-	2	-
10	TE164C	"D" Nut	-	-	2	-
11	TE164D	"D" Washer	-	-	2	-
12	F4707	Exhaust pipe bracket	2	2	-	2
13	DS57	Bracket bolt ($\frac{7}{16}$ " U.H.)	2	2	-	2
14	S26-2	Spring washer	2	2	1	2
15	F879	Nut	2	2	1	2
16	F4265	Pipe to frame clip	-	-	1	-
17	F1369	Clip bolt ($\frac{5}{8}$ " U.H.)	-	-	1	-
18	E4118	Left silencer	1	1	-	1
19	E4119	Right silencer	1	1	-	1
20	E4107	Silencer mute	2	2	-	2
21	H689	Screw ($\frac{1}{4}$ " U.H.)	2	2	-	2
22	H745	Nut	2	2	-	2
23	E3767	Silencer clip	2	2	-	2
24	F3430	Clip bolt (1 $\frac{3}{4}$ " U.H.)	2	2	-	2
25	E3768	"D" Washer	4	4	-	4
26	E1310	Nut	2	2	-	2
27	E4120	Silencer stay	2	2	-	2
28	F3641	Frame stud	1	1	-	1
29	S26-3	Spring washer	3	3	-	3
30	S1-51	Nut	3	3	-	3
31	H426	Silencer hanger bolt ($\frac{3}{16}$ " U.H.)	2	2	-	2
32	E4132	Silencer	-	-	1	-
33	H622	Silencer hanger bolt (1 $\frac{11}{16}$ " U.H.)	-	-	1	-
34	F2694	Distance piece	-	-	1	-
35	S26-1	Spring washer	-	-	1	-
36	S1-52	Nut	-	-	1	-

Complete Assembly
Ref. No. 1.

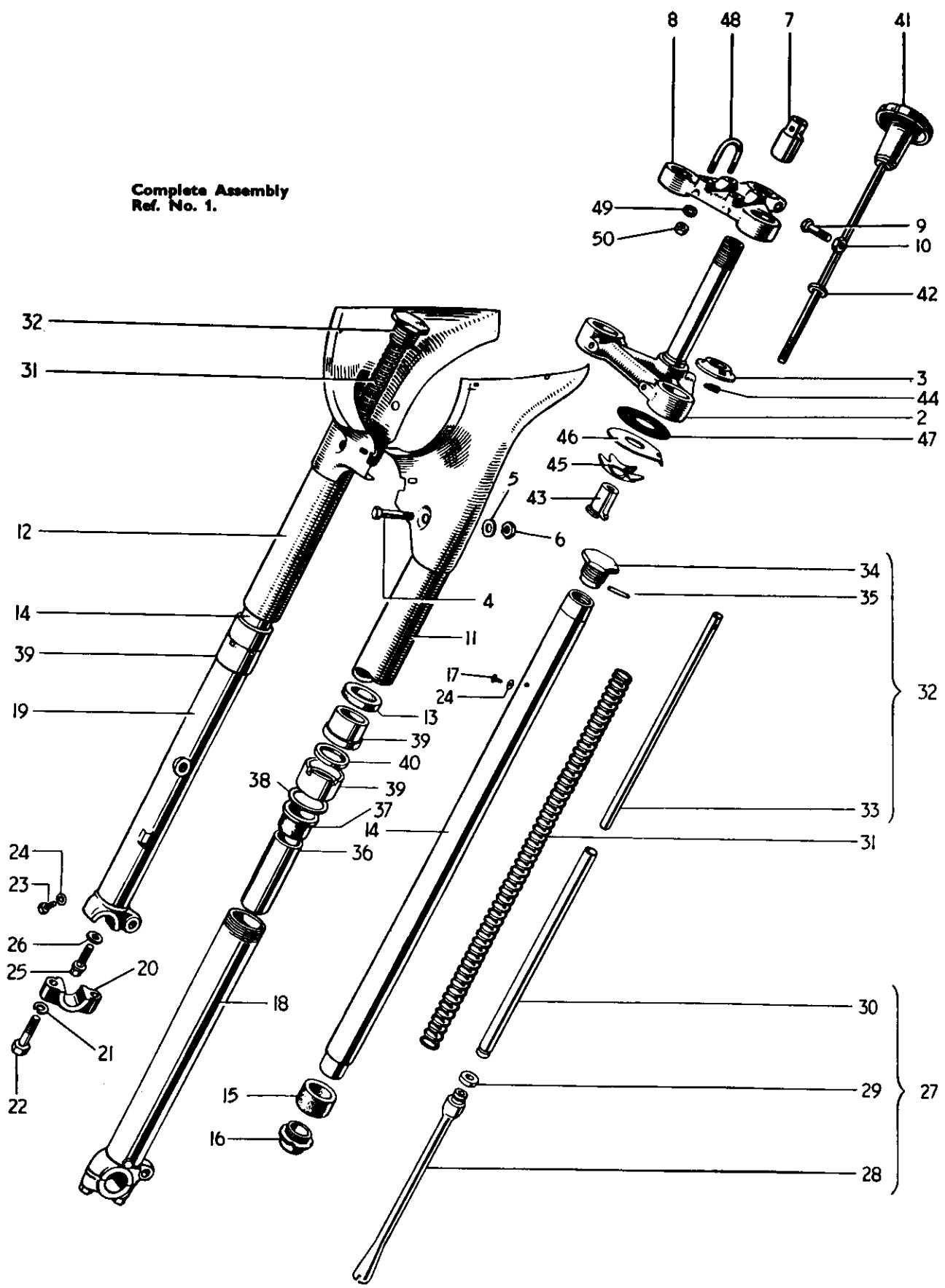

FIG. 16 TELESCOPIC FRONT FORK, 6T AND T110

TELESCOPIC FRONT FORK, 6T & T110

										6T	T110
1	H1310	FORK ASSEMBLY	1	1
2	H1283	Middle lug and stem	1	1
3	H439	Bottom cone	1	1
4	H941	Pinch bolt (2 $\frac{1}{4}$ " U.H.)	2	2
5	S25-2	Plain washer	2	2
6	E2412	Nut	2	2
7	H1141	Fork stem sleeve nut	1	1
8	H1108	Top lug	1	1
9	F1760	Pinch bolt (1 $\frac{11}{16}$ " U.H.)	1	1
10	H379	Seated nut	1	1
11	H1288	Left nacelle cover	1	1
12	H1289	Right nacelle cover	1	1
13	H420	Sponge rubber washer	2	2
14	H1123	STANCHION c/w BEARING	2	2
15	H443	Lower bearing	2	2
16	H1058	Bearing nut	2	2
17	H519A	Oil filler plug ($\frac{3}{16}$ " U.H.)	2	2
18	H1117	LEFT BOTTOM MEMBER c/w CAP	1	1
19	H1118	RIGHT BOTTOM MEMBER c/w CAP	1	1
20	H1053	Spindle cap	2	2
21	S26-3	Spring washer	4	4
22	H1070	Cap bolt (1 $\frac{7}{16}$ " U.H.)	4	4
23	H1071	Drain plug	2	2
24	H430	Fibre washer	4	4
25	H1063	Flanged bolt ($\frac{3}{8}$ " U.H.)	2	2
26	H1062	Aluminium washer	2	2
27	H1124	RESTRICTOR ROD ASSEMBLY	2	2
28	H1061	Restrictor rod	2	2
29	H1060	Plain washer	2	2
30	H1125	Guide tube	2	2
31	H1292	Solo main spring (Black)	2	2
31	H1301	Sidecar main spring (Red/White)	2	2
32	H1064	CAP NUT ASSEMBLY	2	2
33	H1051	Guide tube	2	2
34	H1065	Cap nut	2	2
35	H1066	Pin	2	2
36	H1126	Damping sleeve	2	2
37	H441	Top bearing	2	2
38	H431	Plain washer	2	2
39	H1194	DUST EXCLUDER SLEEVE NUT	2	2
40	H1168	Oil seal	2	2
41	H1142	Steering damper rod c/w knob	1	1
42	H565	Plain washer	1	1
43	H408	Adjuster sleeve	1	1
44	H1286	Locating pin	1	1
45	H95	Spring plate	1	1
46	H1285	Anchor plate	1	1
47	H435	Friction disc	1	1
48	H660	Handlebar "U" bolt	2	2
49	S25-3	Plain washer	4	4
50	E1310	Nut	4	4

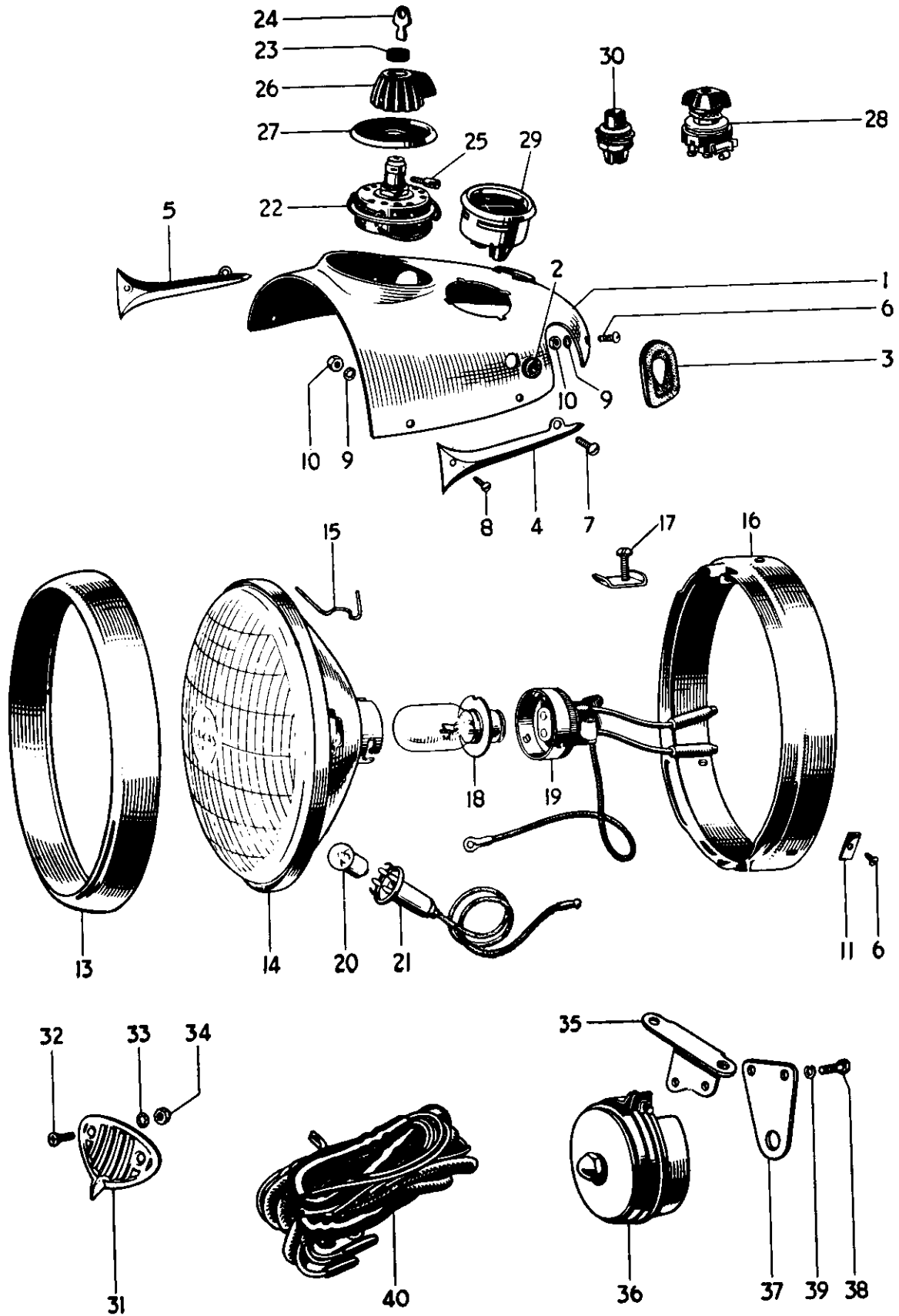

FIG. 17 NACELLE, HEADLAMP AND SWITCHES

NACELLE, HEADLAMP AND SWITCHES

												6T	T110
1	H1144	Nacelle top	1	-
1	H1298	Nacelle top	-	1
2	H961	Rubber grommet	3	3
3	H669	Rubber grommet	2	2
4	H877	Left motif	1	1
5	H878	Right motif	1	1
6	H689	Screw ($\frac{1}{4}$ " U.H.)	4	4
7	H688	Screw ($\frac{5}{16}$ " U.H.)	2	2
8	H687	Screw ($\frac{3}{8}$ " U.H.)	2	2
9	E2880	Serrated washer	4	4
10	H691	Nut	4	4
11	H690	Nut	2	2
12	51860	HEADLAMP	1	1
13	553248	Rim	1	1
14	516812	Light unit	1	1
15	504665	Fixing wire	6	6
16	553267	Fixing ring	1	1
17	534296	Screw and plate	1	1
18	373	Bulb (30/24W. L.H. dipping, Pre-focus)	1	1
19	554602	Adaptor	1	1
20	988	Bulb (3W.M.C.C.)	1	1
21	554710	Pilot bulbholder	1	1
22	31443	LIGHTING AND IGNITION SWITCH (P.R.S.8)	1	-
23	318323	Grommet	1	-
24	318341	Key	1	-
25	319333	Screw	1	-
26	318346	Knob	1	-
27	318343	Index plate	1	-
28	31784	Lighting switch (S.A.41)	-	1
29	36189	Ammeter	1	1
30	31071	Cut-out button (S.S.5)	-	1
31	H992	Horn grille	1	1
32	H993	Screw (0.540" U.H.)	2	2
33	GS299	Serrated washer	2	2
34	F3799	Nut	2	2
35	H1172	Horn bracket	1	1
36	70048	Horn	1	1
37	701851	Fixing plate	2	2
38	142689	Screw	2	2
39	185051	Spring washer	2	2
40	54094162	Wiring harness	1	-
40	54094163	Wiring harness	-	1

Complete Assembly
Ref. No. 1.

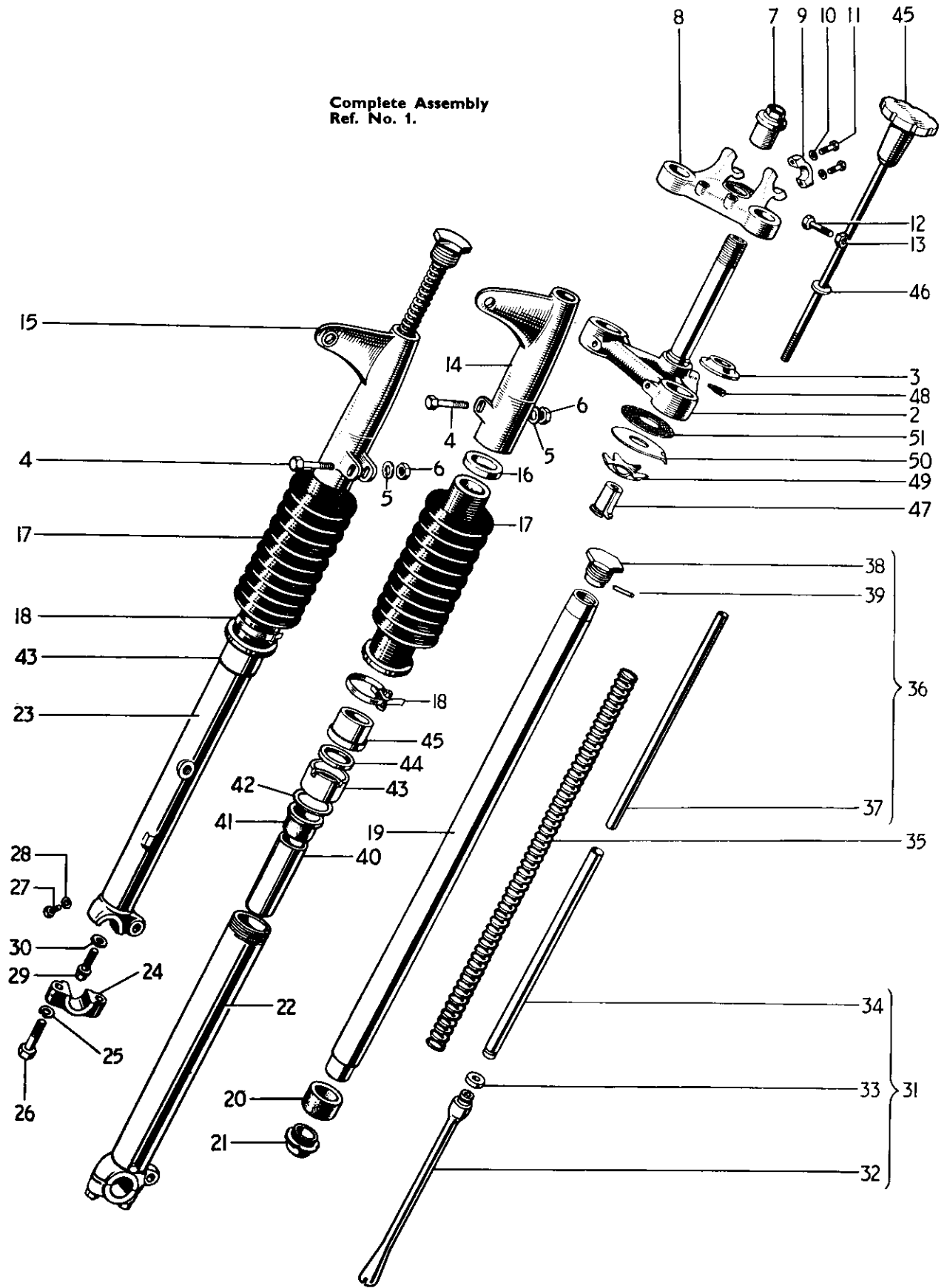

FIG. 18 TELESCOPIC FRONT FORK, TR6 AND T120

TELESCOPIC FRONT FORK, TR6 & T120

											TR6	T120
1	H1311	FORK ASSEMBLY	1	1
2	H1283	Middle lug and stem	1	1
3	H439	Bottom cone	1	1
4	H941	Pinch bolt (2½" U.H.)	2	2
5	S25-2	Plain washer	2	2
6	E2412	Nut	2	2
7	H405	Fork stem sleeve nut	1	1
8	H1287	TOP LUG c/w CAPS	1	1
9	H506	Handlebar cap	2	2
10	S25-3	Plain washer	4	4
11	H436	Clamping bolt (⅞" U.H.)	4	4
12	F1760	Pinch bolt (1⅞" U.H.)	1	1
13	H379	Seated nut	1	1
14	H963	Left nacelle cover	1	1
15	H964	Right nacelle cover	1	1
16	H420	Sponge rubber washer	2	2
17	H962	Telescopic gaiter	2	2
18	D340	Gaiter clip	2	2
19	H1299	STANCHION c/w BEARING	2	2
20	H443	Lower bearing	2	2
21	H1058	Bearing nut	2	2
22	H1117	LEFT BOTTOM MEMBER c/w CAP	1	1
23	H1118	RIGHT BOTTOM MEMBER c/w CAP	1	1
24	H1053	Spindle cap	2	2
25	S26-3	Spring washer	4	4
26	H1070	Cap bolt (1⅞" U.H.)	4	4
27	H1071	Drain plug	2	2
28	H430	Fibre washer	2	2
29	H1063	Flanged bolt (⅝" U.H.)	2	2
30	H1062	Aluminium washer	2	2
31	H1124	RESTRICTOR ROD ASSEMBLY	2	2
32	H1061	Restrictor rod	2	2
33	H1060	Plain washer	2	2
34	H1125	Guide tube	2	2
35	H1300	Solo main spring (Black/White)	2	2
35	H1305	Sidecar main spring (Black/Red)	2	2
36	H1064A	CAP NUT ASSEMBLY	2	2
37	H1051	Guide tube	2	2
38	H1065A	Cap nut	2	2
39	H1066	Pin	2	2
40	H1126	Damping sleeve	2	2
41	H441	Top bearing	2	2
42	H431	Plain washer	2	2
43	H1194	DUST EXCLUDER SLEEVE NUT	2	2
44	H1168	Oil seal	2	2
45	H1142	Steering damper rod c/w knob	1	1
46	H565	Plain washer	1	1
47	H408	Adjuster sleeve	1	1
48	H1286	Locating pin	1	1
49	H95	Spring plate	1	1
50	H1285	Anchor plate	1	1
51	H435	Friction disc	1	1

Complete Assembly
Ref. No. 1.

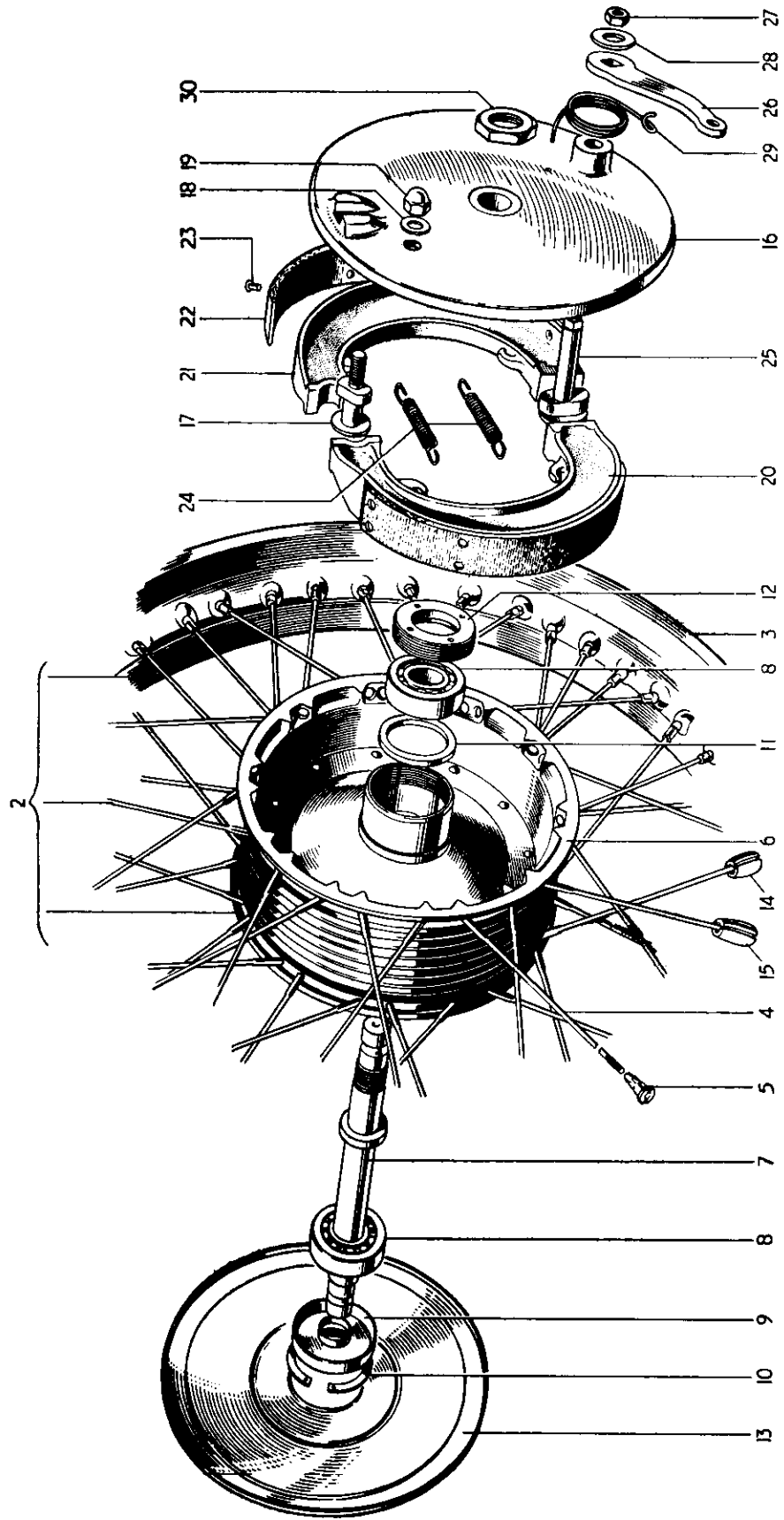
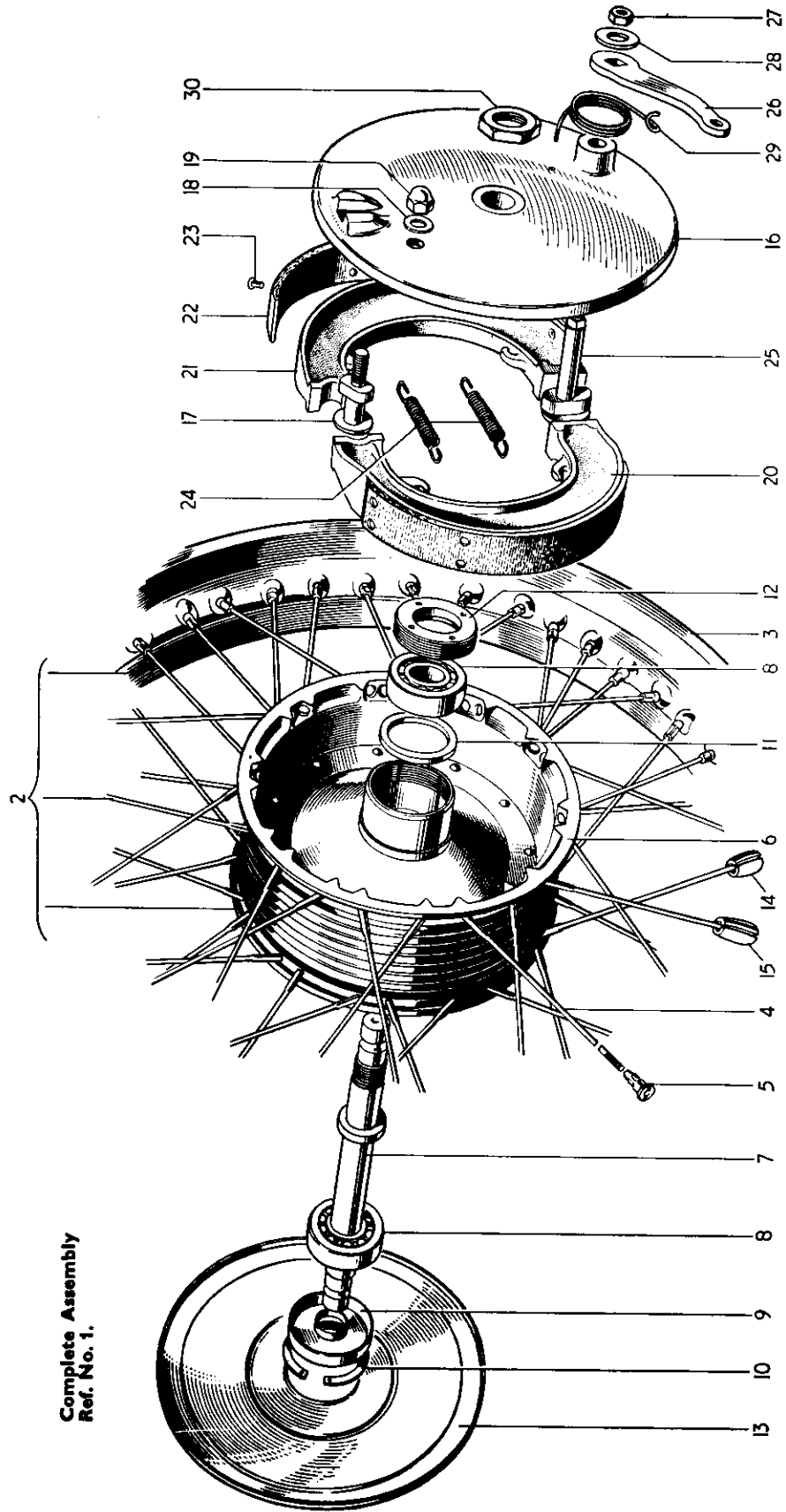

FIG. 19 FRONT WHEEL, 6T

FRONT WHEEL, 6T

Ref. No.	Part No.	DESCRIPTION	QUANTITY
			6T
1	W1398	FRONT WHEEL COMPLETE	1
2	W1370	RIM, SPOKES AND HUB ASSEMBLY	1
3	W1373	Front wheel rim WM2-18	1
4	W1328	Spoke (8/10G × 5 $\frac{3}{8}$ ", straight) c/w nipple	40
5	S79-2	Spoke nipple	40
6	W1231	Hub and brake drum	1
7	W1239	Wheel spindle	1
8	W653	Bearing	2
9	W1237	Dust cover	1
10	T280	Circlip	1
11	W1238	Backing ring	1
12	W582	Retaining ring	1
13	W1334	Cover plate	1
14	W1197	Balance weight, $\frac{1}{2}$ oz.	} ... as required
15	W1198	Balance weight, 1 oz.	
16	W1301	Brake anchor plate	1
17	W1302	Fulcrum pin	1
18	S25-2	Plain washer	1
19	E1435	Domed nut	1
20	W93	BRAKE SHOE c/w LINING	1
21	W93	BRAKE SHOE c/w LINING	1
22	NW243	Brake lining	2
23	W129	Brass rivet	16
24	W135	Shoe return spring	2
25	W1243	Brake cam	1
26	W1298X	Brake cam lever	1
27	S1-52	Nut	1
28	S25-6	Plain washer	1
29	W592	Lever return spring	1
30	W1246	Anchor plate nut	1



Complete Assembly
Ref. No. 1.

FIG. 20 FRONT WHEEL, T110, TR6 AND T120

FRONT WHEEL, T110, TR6 & T120

			T110	TR6	T120
1	W1399	FRONT WHEEL COMPLETE	1	-	-
1	W1323	FRONT WHEEL COMPLETE	-	1	1
2	W1371	RIM, SPOKES AND HUB ASSEMBLY	1	-	-
2	W1324	RIM, SPOKES AND HUB ASSEMBLY	-	1	1
3	W1374	Front wheel rim (WM2-18)	1	-	-
3	W1230	Front wheel rim (WM2-19)	-	1	1
4	W1275	Spoke (8/10G × 5 $\frac{1}{16}$ " , straight) c/w nipple	40	-	-
4	W1328	Spoke (8/10G × 5 $\frac{1}{8}$ " , straight) c/w nipple	-	40	40
5	S79-2	Spoke nipple	40	40	40
6	W1325	Hub and brake drum	1	1	1
7	W1239	Wheel spindle	1	1	1
8	W653	Bearing	2	2	2
9	W1237	Dust cover	1	1	1
10	T280	Circlip	1	1	1
11	W1238	Backing ring	1	1	1
12	W582	Retaining ring	1	1	1
13	W1332	Cover plate	1	1	1
14	W1197	Balance weight, $\frac{1}{2}$ oz. }	as required		
15	W1198	Balance weight, 1 oz. }			
16	W1330	Brake anchor plate	1	1	1
17	W1302	Fulcrum pin	1	1	1
18	S25-2	Plain washer	1	1	1
19	E1435	Domed nut	1	1	1
20	W1337	LEADING BRAKE SHOE c/w LINING	1	1	1
21	W1338	TRAILING BRAKE SHOE c/w LINING	1	1	1
22	W1336	Brake lining	2	2	2
23	W129	Brass rivet	16	16	16
24	W135	Shoe return spring	2	2	2
25	W1243	Brake cam	1	1	1
26	W1331X	Brake cam lever	1	1	1
27	S1-52	Nut	1	1	1
28	S25-6	Plain washer	1	1	1
29	W592	Lever return spring	1	1	1
30	W1246	Anchor plate nut	1	1	1

Complete Assembly
Ref. No. 1

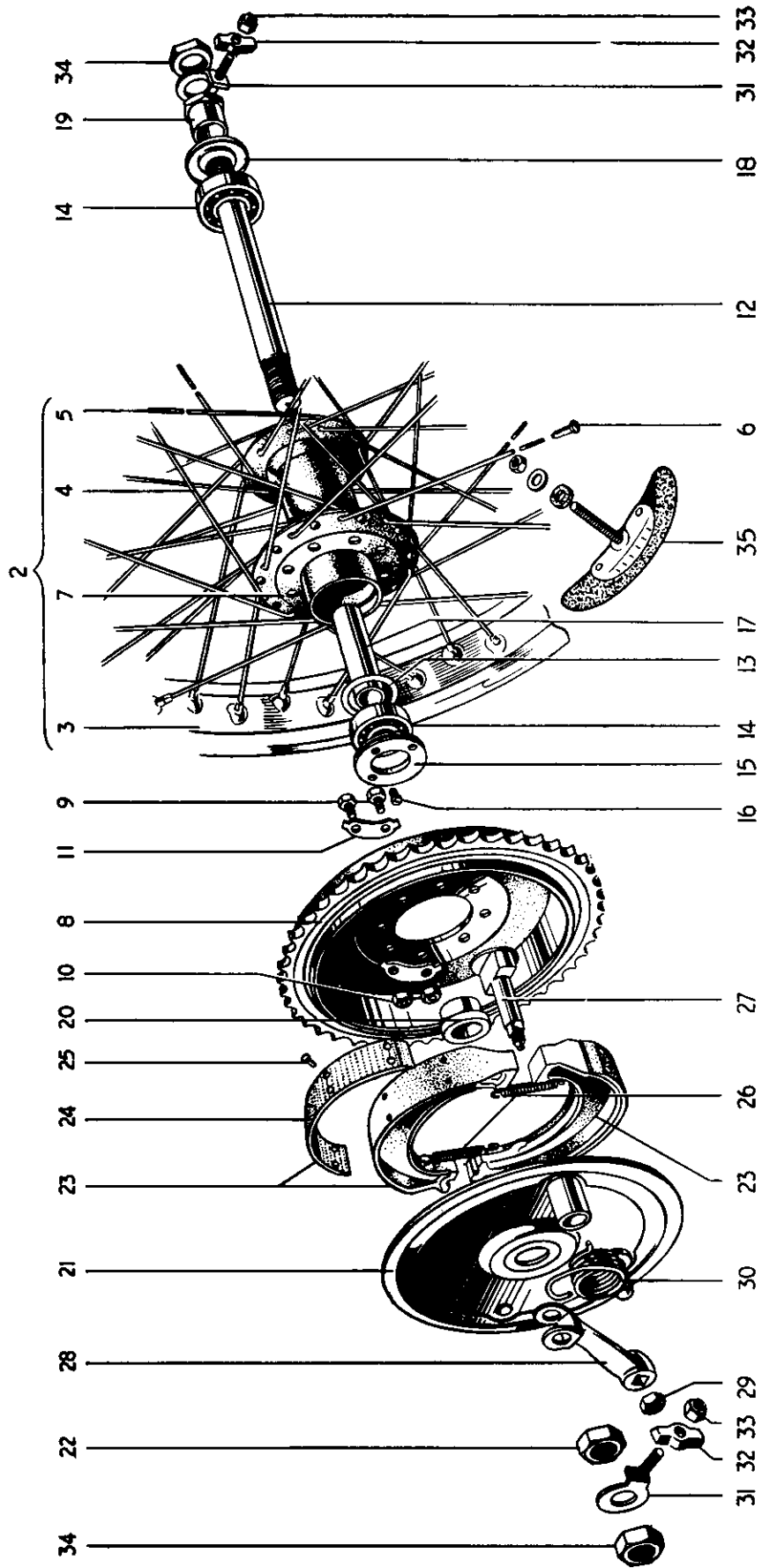

FIG. 21 REAR WHEEL

Ref. No.	Part No.	DESCRIPTION	6T	T110	TR6	T120
REAR WHEEL						
1	W1400	REAR WHEEL COMPLETE	1	1	-	-
1	W1401	REAR WHEEL COMPLETE	-	-	1	-
1	W1402	REAR WHEEL COMPLETE	-	-	-	1
2	W1372	RIM, SPOKES AND HUB ASSEMBLY	1	1	-	-
2	W1308	RIM, SPOKES AND HUB ASSEMBLY	-	-	1	-
2	W1306	RIM, SPOKES AND HUB ASSEMBLY	-	-	-	1
3	W1378	Rear wheel rim (WM2-18)	1	1	-	-
3	W1007	Rear wheel rim (WM3-18)	-	-	1	-
3	W79A	Rear wheel rim (WM2-19)	-	-	-	1
4	W1107	Spoke (8/10G × 7 $\frac{3}{8}$ " 90°) c/w nipple	20	20	20	-
4	W1104	Spoke (8/10G × 8" 90°) c/w nipple	-	-	-	20
5	W1108	Spoke (8/10G × 7 $\frac{7}{8}$ " 90°) c/w nipple	20	20	20	-
5	W1106	Spoke (8/10G × 8 $\frac{3}{8}$ " 90°) c/w nipple	-	-	-	20
6	S79-2	Spoke nipple	40	40	40	40
7	W1158	Hub	1	1	1	1
8	W1276	Sprocket and brake drum (43T)	1	1	1	1
9	W62	Sprocket to hub bolt ($\frac{11}{16}$ " U.H.)	8	8	8	8
10	S1-51	Nut	8	8	8	8
11	W63	Sprocket bolt lockplate	8	8	8	8
12	W1025	Wheel spindle	1	1	1	1
13	W1022	Backing ring	1	1	1	1
14	W653	Bearing	2	2	2	2
15	W1021	RETAINING RING	1	1	1	1
16	W1079	Locking screw ($\frac{5}{16}$ " U.H.)	1	1	1	1
17	W1023	Distance tube	1	1	1	1
18	W583	Dust cover	1	1	1	1
19	W1026	Nut	1	1	1	1
20	W1024	Distance piece	1	1	1	1
21	W1112	Brake anchor plate	1	1	1	1
22	F1747	Nut	1	1	1	1
23	W93	BRAKE SHOE c/w LINING	2	2	2	2
24	NW243	Brake lining	2	2	2	2
25	W129	Brass rivet	16	16	16	16
26	W135	Shoe return spring	2	2	2	2
27	W1083	Brake cam	1	1	1	1
28	W1085	Brake cam lever	1	1	1	1
29	S1-52	Nut	1	1	1	1
30	W1090	Lever return spring	1	1	1	1
31	W1134	Chain adjuster	2	2	2	2
32	W1015	Adjuster end plate	2	2	2	2
33	W1058	Self-locking nut	2	2	2	2
34	F1747	Spindle nut	2	2	2	2
35	D106	Tyre security bolt	1	1	-	1
35	WM3	Tyre security bolt	-	-	1	-

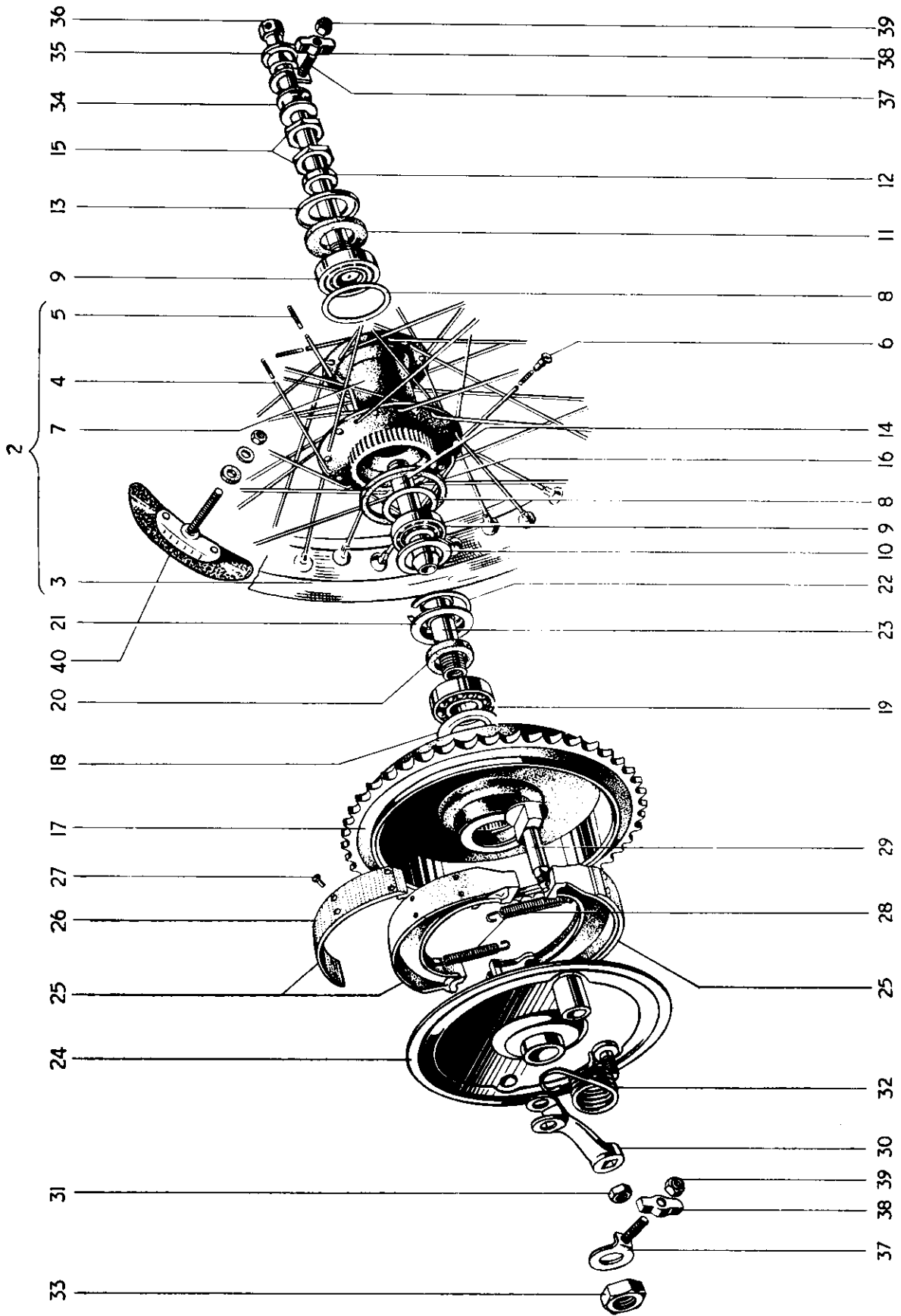

FIG. 22 QUICKLY DETACHABLE REAR WHEEL

QUICKLY DETACHABLE REAR WHEEL

						6T	T110	TR6	T120
1	W1403	Q.D. REAR WHEEL COMPLETE	1	1	-	-
1	W1404	Q.D. REAR WHEEL COMPLETE	-	-	1	-
1	W1405	Q.D. REAR WHEEL COMPLETE	-	-	-	1
2	W1375	RIM, SPOKES AND HUB ASSEMBLY	1	1	-	-
2	W1099	RIM, SPOKES AND HUB ASSEMBLY	-	-	1	-
2	W1098	RIM, SPOKES AND HUB ASSEMBLY	-	-	-	1
3	W1378	Rear wheel rim (WM2-18)	1	1	-	-
3	W1007	Rear wheel rim (WM3-18)	-	-	1	-
3	W79A	Rear wheel rim (WM2-19)	-	-	-	1
4	W1107	Spoke (8/10G × 7 $\frac{9}{16}$ " 90°) c/w nipple	20	20	20	-
4	W1104	Spoke (8/10G × 8" 90°) c/w nipple	-	-	-	20
5	W1108	Spoke (8/10G × 7 $\frac{7}{8}$ " 90°) c/w nipple	20	20	20	20
5	W1106	Spoke (8/10G × 8 $\frac{3}{8}$ " 90°) c/w nipple	-	-	-	-
6	S79-2	Spoke nipple	40	40	40	40
7	W1100	Hub	1	1	1	1
8	W1033	Backing ring	2	2	2	2
9	W1034	Taper roller bearing complete	2	2	2	2
10	W1035	Dust cap	1	1	1	1
11	W1036	Felt washer	1	1	1	1
12	W1037	Distance piece	1	1	1	1
13	W1038	Dust cap	1	1	1	1
14	W1039	Bearing sleeve	1	1	1	1
15	E398	Bearing adjuster nut	2	2	2	2
16	W1091	Rubber sealing ring	1	1	1	1
17	W1376	Sprocket and brake drum (43T)	1	1	1	1
18	W1143	Grease retainer	1	1	1	1
19	W1041	Bearing	1	1	1	1
20	W1042	Felt washer	1	1	1	1
21	W1043	Bearing and felt retainer	1	1	1	1
22	W1044	Circlip	1	1	1	1
23	W1045	Bearing sleeve	1	1	1	1
24	W1121	Brake anchor plate	1	1	1	1
25	W93	BRAKE SHOE c/w LINING	2	2	2	2
26	NW243	Brake lining	2	2	2	2
27	W129	Brass rivet	16	16	16	16
28	W135	Shoe return spring	2	2	2	2
29	W1083	Brake cam	1	1	1	1
30	W1085	Brake cam lever	1	1	1	1
31	S1-52	Nut	1	1	1	1
32	W1090	Lever return spring	1	1	1	1
33	W1052	Nut	1	1	1	1
34	W1053	Inner distance piece	1	1	1	1
35	W1170	Outer distance piece	1	1	1	1
36	W1055	Spindle	1	1	1	1
37	W1135	Chain adjuster	2	2	2	2
38	W1015	Adjuster end plate	2	2	2	2
39	W1058	Self-locking nut	2	2	2	2
40	D106	Tyre security bolt	1	1	-	1
40	WM3	Tyre security bolt	-	-	1	-

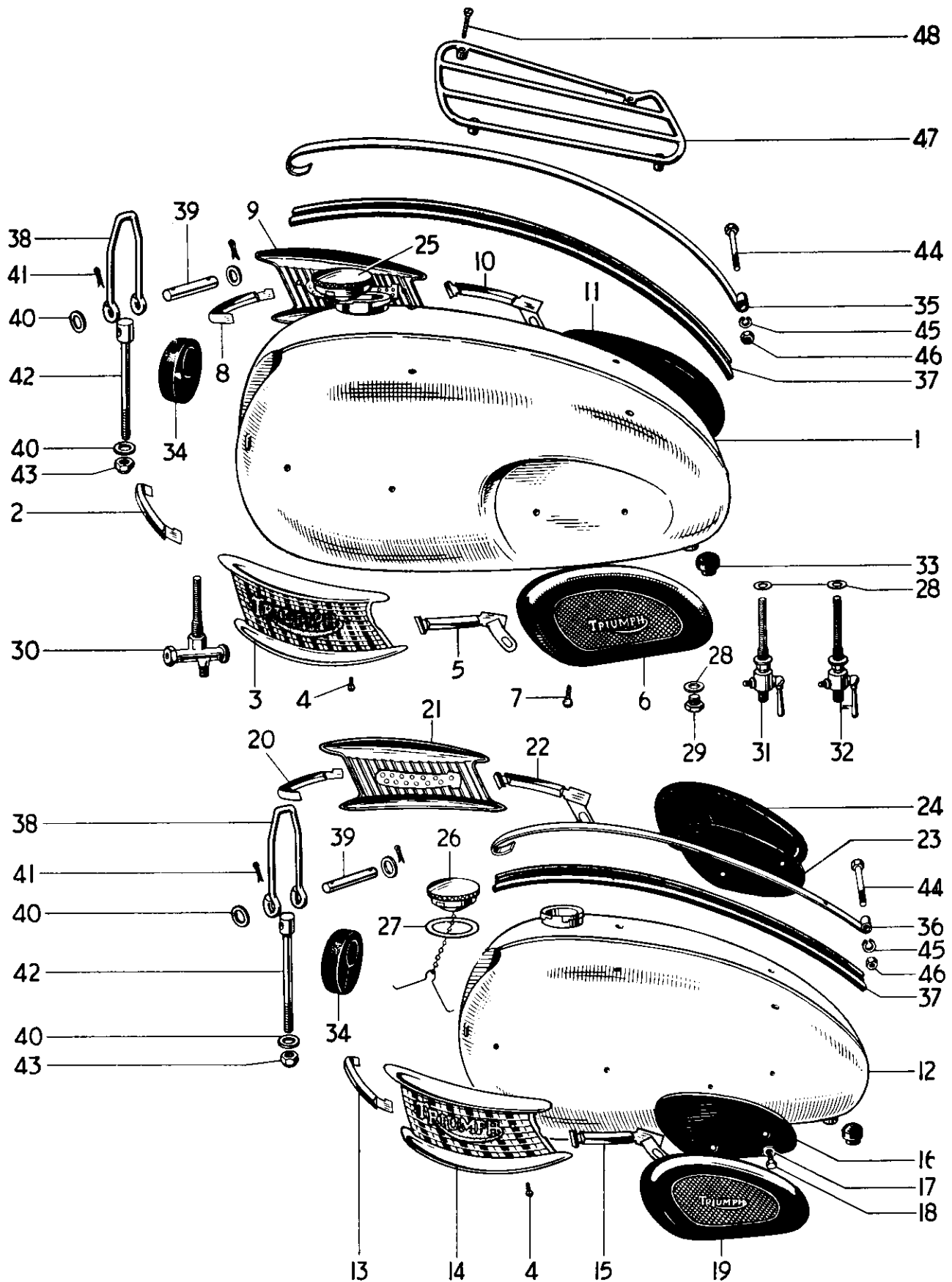

FIG. 23 PETROL TANKS

Ref. No.	Part No.	DESCRIPTION	QUANTITY			
PETROL TANKS						
			6T	T110	TR6	T120
1	F4640	Petrol tank (4 gallons)	1	1	-	1
2	F4148	Styling strip (left, front)	1	1	-	1
3	F4766	Styling unit (left)	1	1	-	1
4	F4129	Styling unit screw (0.435" U.H.)	4	4	4	4
5	F4665	Styling strip (left, rear)	1	1	-	1
6	F2551	Knee grip (left)	1	1	-	1
7	F1953	Knee grip screw ($\frac{5}{8}$ " U.H.)	4	4	-	4
8	F4551	Styling strip (right, front)	1	1	-	1
9	F4767	Styling unit (right)	1	1	-	1
10	F4667	Styling strip (right, rear)	1	1	-	1
11	F2552	Knee grip (right)	1	1	-	1
12	F4700	Petrol tank (3 gallons)	-	-	1	-
13	F4235	Styling strip (left, front)	-	-	1	-
14	F4127	Styling unit (left)	-	-	1	-
15	F4236	Styling strip (left, rear)	-	-	1	-
16	F3915	Knee grip plate (left)	-	-	1	-
17	S25-13	Plain washer	-	-	4	-
18	T361	Knee grip plate bolt ($\frac{1}{4}$ " U.H.)	-	-	4	-
19	F1606	Knee grip (left)	-	-	1	-
20	F4237	Styling strip (right, front)	-	-	1	-
21	F4128	Styling unit (right)	-	-	1	-
22	F4238	Styling strip (right, rear)	-	-	1	-
23	F3916	Knee grip plate (right)	-	-	1	-
24	F1605	Knee grip (right)	-	-	1	-
25	F3220	FILLER CAP	1	1	-	1
26	F3219	FILLER CAP c/w JACK CHAIN	-	-	1	-
27	F4048	Joint washer	1	1	1	1
28	F1511	Fibre washer	2	2	2	2
29	F3329	Blanking plug	1	-	-	-
30	F1717	Petrol tap	1	-	-	-
31	F3057	Petrol tap (left)	-	1	1	2
32	F3116	Petrol tap with reserve tube	-	1	1	-
33	F4641	Mounting rubber	3	3	3	3
34	F4770	Steady rubber	1	1	1	1
35	F4655	Securing strap	1	1	-	1
36	F4699	Securing strap	-	-	1	-
37	F4657	Securing strap rubber	1	1	1	1
38	F4658	Front yoke	1	1	1	1
39	F4656	Yoke pin	1	1	1	1
40	S25-3	Plain washer	3	3	3	3
41	$\frac{1}{16}$ " \times $\frac{1}{2}$ "	Split pin	2	2	2	2
42	F4659	Eyebolt	1	1	1	1
43	W1058	Self-locking nut	1	1	1	1
44	F2596	Rear bolt ($1\frac{1}{8}$ " U.H.)	1	1	1	1
45	S26-2	Spring washer	1	1	1	1
46	S1-51	Nut	1	1	1	1
47	F3917	Parcel grid	1	1	1	1
48	F2936	Parcel grid screw	4	4	4	4

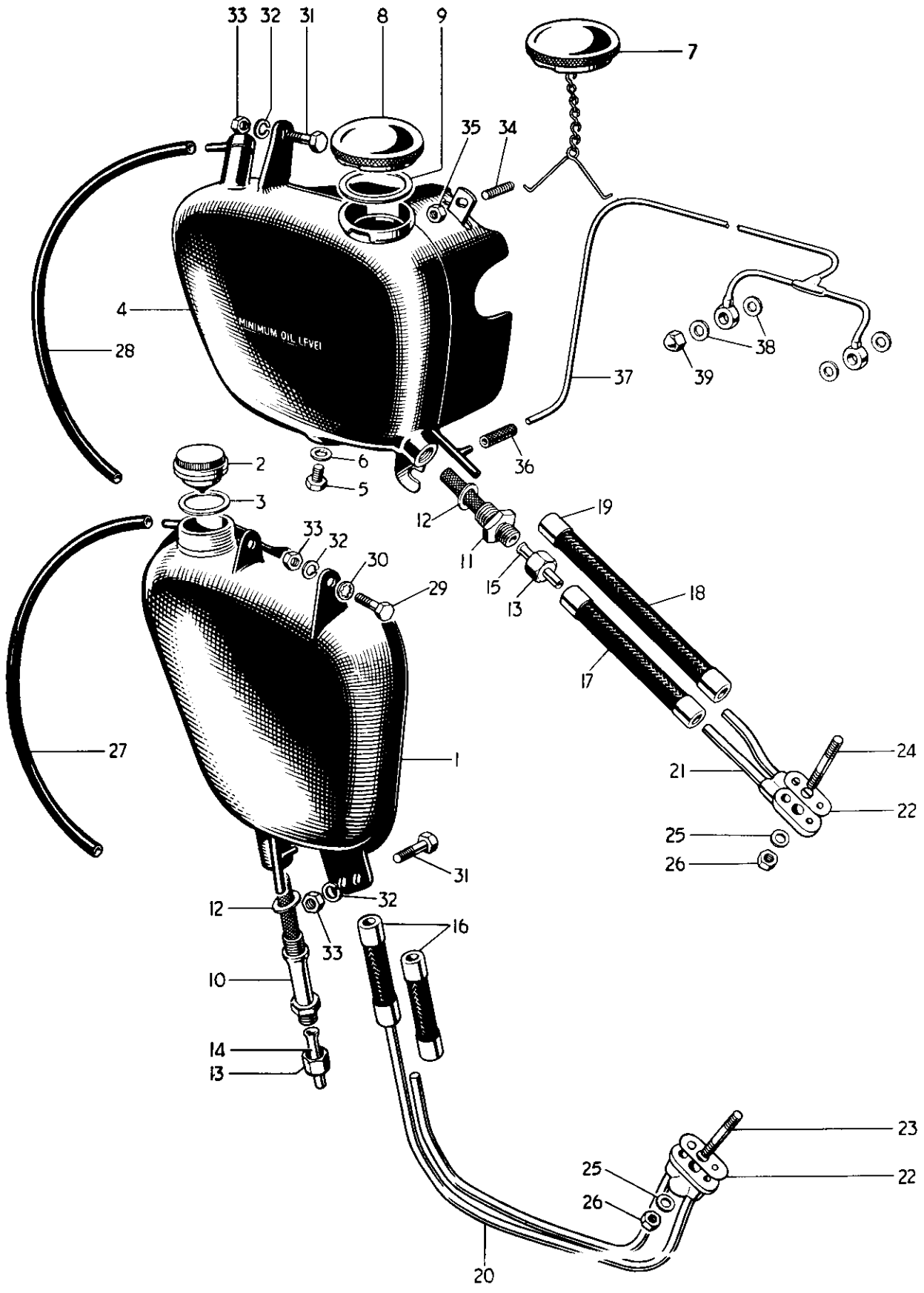

FIG. 24 OIL TANKS

Ref. No.	Part No.	DESCRIPTION	6T	T110	TR6	T120
OIL TANKS						
1	F4476A	Oil tank	1	1	-	-
2	F4477	FILLER CAP	1	1	-	-
3	F4478	Joint washer	1	1	-	-
4	F4702	Oil tank	-	-	1	1
5	F1792	Drain plug	-	-	1	1
6	PT104B	Fibre washer	-	-	1	1
7	F3796	FILLER CAP c/w JACK CHAIN	-	-	1	-
8	F3658	FILLER CAP	-	-	-	1
9	F4048	Joint washer	-	-	1	1
10	F4533	Oil tank filter	1	1	-	-
11	F3179	Oil tank filter	-	-	1	1
12	F1713	Fibre washer	1	1	1	1
13	F3182	Union nut	1	1	1	1
14	E4113	Upper feed pipe	1	1	-	-
15	F3655	Upper feed pipe	-	-	1	1
16	MF119/20	Rubber connector	2	2	-	-
17	E3353	Rubber feed pipe	-	-	1	1
18	E3354	Rubber return pipe	-	-	1	1
19	MF120	Ferrule	-	-	2	2
20	E4109	Oil pipes and junction block	1	1	-	-
21	E3355	Oil pipes and junction block	-	-	1	1
22	E1529	Joint washer	1	1	1	1
23	E4114	Crankcase stud (1½" O.A.)	1	1	-	-
24	E1539	Crankcase stud (1¾" O.A.)	-	-	1	1
25	S25-3	Plain washer	1	1	1	1
26	S1-51	Nut	1	1	1	1
27	T1579	Vent pipe	1	1	-	-
28	T1578	Vent pipe	-	-	1	1
29	F1213	Bolt (11/16" U.H.)	2	2	1	1
30	E2287	Serrated washer	1	1	-	-
31	F2335	Bolt (11/16" U.H.)	1	1	1	1
32	S26-3	Spring washer	3	3	2	2
33	S1-51	Nut	3	3	2	2
34	F3641	Stud (11/8" O.A.)	-	-	1	1
35	F1008	Nut	-	-	1	1
36	E3383	Rubber connector	1	1	1	1
37	E4159	Rocker oil feed pipe	1	1	1	1
38	E1335	Copper washer	4	4	4	4
39	E1435	Domed nut	2	2	2	2

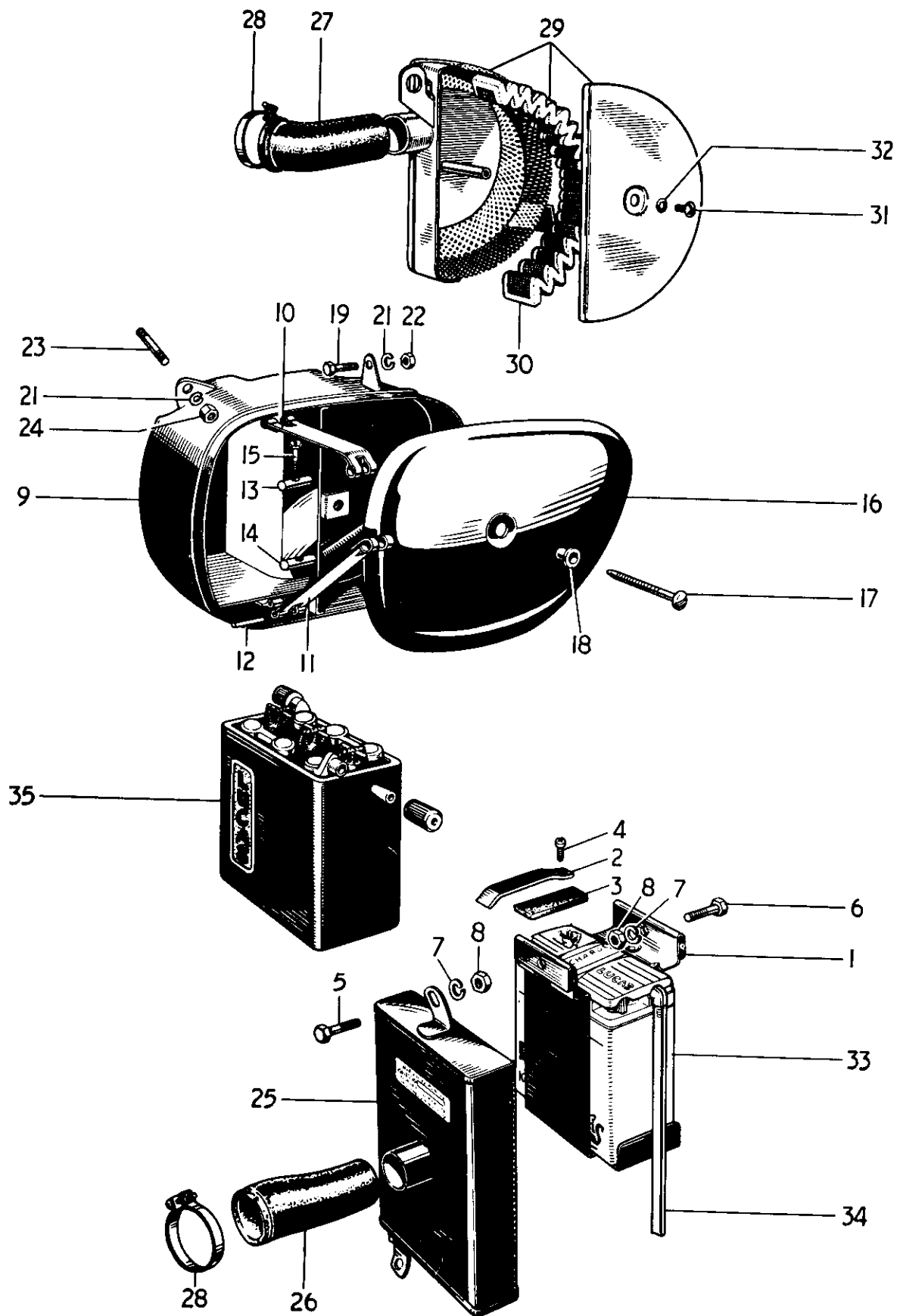

FIG. 25 BATTERY CARRIER AND AIR FILTER

Ref. No.	Part No.	DESCRIPTION	6T	T110	TR6	T120
BATTERY CARRIER AND AIR FILTER						
1	F4660	Battery carrier	1	1	-	-
2	F4661	Top strap	1	1	-	-
3	F4662	Packing rubber	1	1	-	-
4	E3200	Screw ($\frac{11}{16}$ " U.H.)	1	1	-	-
5	F1369	Bolt ($\frac{5}{8}$ " U.H.)	1	1	-	-
6	DS57	Bolt ($\frac{7}{16}$ " U.H.)	1	1	-	-
7	S25-1	Plain washer	2	2	-	-
8	F879	Nut	2	2	-	-
9	F4705	BATTERY CASE AND TOOLBOX	-	-	1	-
9	F4706	BATTERY CASE AND TOOLBOX	-	-	-	1
10	F3588	Top strap	-	-	1	1
11	F1668	Side strap	-	-	1	1
12	F1727	Hinge pin	-	-	2	2
13	E534	Plain swivel	-	-	1	1
14	E535	Threaded swivel	-	-	1	1
15	E536	Bolt ($1\frac{11}{16}$ " U.H.)	-	-	1	1
16	F3874	TOOLBOX LID	-	-	1	1
17	F3875	Lid fastener	-	-	1	1
18	F3227	Aluminium grommet	-	-	1	1
29	F1213	Bolt ($\frac{11}{16}$ " U.H.)	-	-	1	1
20	F2335	Bolt ($\frac{11}{16}$ " U.H.)	-	-	1	1
21	S26-3	Spring washer	-	-	3	3
22	S1-51	Nut	-	-	2	2
23	F3641	Stud ($\frac{11}{16}$ " O.A.)	-	-	1	1
24	F1008	Nut	-	-	1	1
25	F4673	Air filter	1	1	-	-
26	F4672	Rubber connector	1	1	-	-
27	F3858	Rubber connector	1	1	-	-
28	F3859	Clip	1	1	1	-
29	F4698	AIR FILTER	-	-	1	-
30	F3315E	Element only	-	-	1	-
31	F3376	Screw ($\frac{3}{8}$ in. U.H.)	-	-	1	-
32	E1612	Serrated washer	-	-	1	-
33	MLZ9E	Battery c/w lid	1	1	-	-
34	F4814	Plastic vent pipe	1	1	-	-
35	PU7E-9	Battery	-	-	1	1

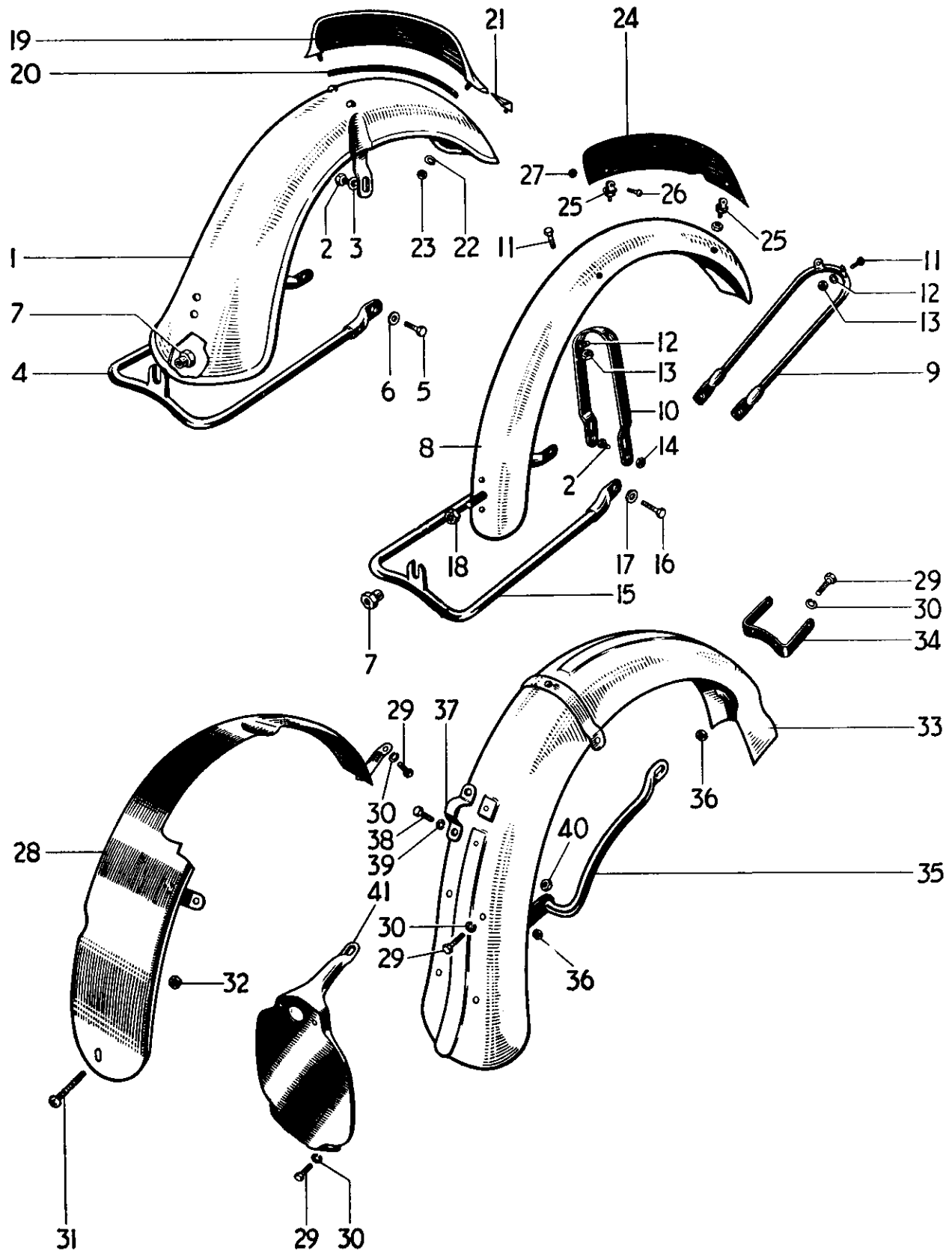

FIG. 26 MUDGUARDS

Ref. No.	Part No.	DESCRIPTION	QUANTITY			
			6T	T110	TR6	T120
1	H1097	Front mudguard	1	1	-	-
2	F929	Bolt ($\frac{1}{2}$ " U.H.)	2	2	4	4
3	F4299	Plain washer	2	2	2	2
4	H1100	Bottom stay ...	1	1	-	-
5	W62	Bolt ($\frac{11}{16}$ " U.H.)	2	2	-	-
6	S25-2	Plain washer	2	2	-	-
7	NS362	Spigot nut ...	1	1	1	1
8	H1294	Mudguard blade	-	-	1	1
9	H1271	Front stay ...	-	-	1	1
10	H1295	Mudguard bridge	-	-	1	1
11	DS57	Bolt ($\frac{7}{8}$ " U.H.)	-	-	4	4
12	S25-1	Plain washer	-	-	4	4
13	F879	Nut ...	-	-	4	4
14	T224	Nut ...	-	-	2	2
15	H412	Bottom stay ...	-	-	1	1
16	H424	Bolt ($\frac{3}{8}$ " U.H.)	-	-	2	2
17	S25-71	Plain washer	-	-	2	2
18	S1-51	Nut ...	-	-	1	1
19	F2698	Number plate	1	1	-	-
20	H251	Plate beading	1	1	-	-
21	F4332	Packing piece	1	1	-	-
22	S26-2	Spring washer	2	2	-	-
23	F879	Nut ...	2	2	-	-
24	F2996	Number plate	-	-	1	1
25	H741	Clip assembly	-	-	2	2
26	H687	Screw ($\frac{3}{8}$ " U.H.)	-	-	2	2
27	H745	Nut ...	-	-	2	2
28	F4674	Rear mudguard	1	1	-	-
29	DS57	Bolt ($\frac{7}{8}$ " U.H.)	1	1	6	6
30	S26-2	Spring washer	1	1	6	6
31	F4716	Screw ($1\frac{1}{8}$ " U.H.)	1	1	-	-
32	F4717	Nut ...	1	1	-	-
33	F4687	Rear mudguard	-	-	1	1
34	F3599	Bracket ...	-	-	1	1
35	F3896	Lifting handle	-	-	1	1
36	F879	Nut ...	-	-	6	6
37	F4690	Clip ...	-	-	1	1
38	F929	Bolt ($\frac{1}{2}$ " U.H.)	-	-	2	2
39	S26-3	Spring washer	-	-	2	2
40	S1-51	Nut ...	-	-	2	2
41	F3363	Number plate	-	-	1	1

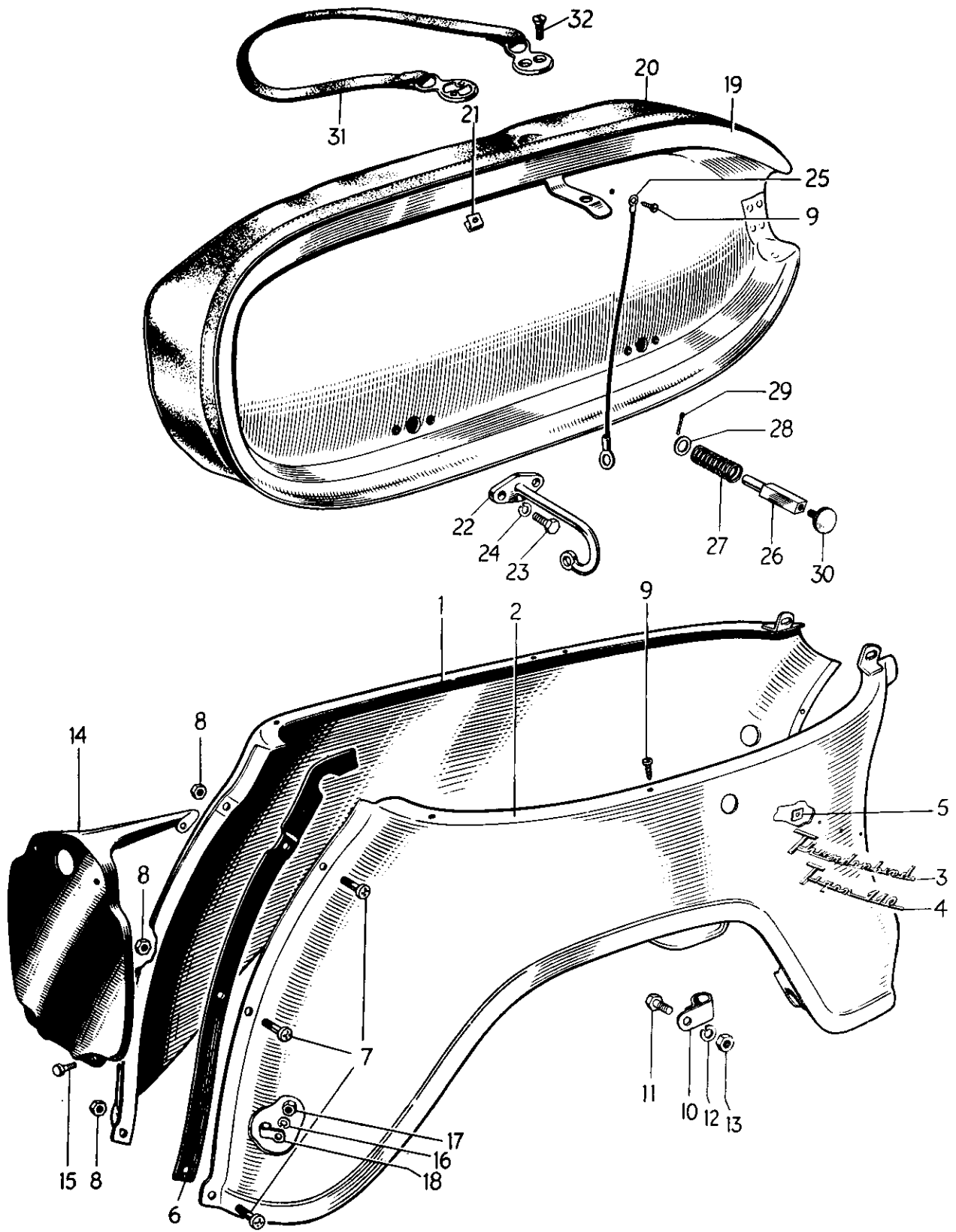

FIG. 27 PANELS AND TWINSEAT

Ref. No.	Part No.	DESCRIPTION	QUANTITY			
PANELS AND TWINSEAT			6T	T110	TR6	T120
1	F4676	Left panel	1	1	-	-
2	F4677	Right panel	1	1	-	-
3	F4663	Motif "Thunderbird"	2	-	-	-
4	F4664	Motif "Tiger 110"	-	2	-	-
5	F4317	Spire nut	6	6	-	-
6	F4249	Joint beading	2	2	-	-
7	F4715	Screw ($\frac{11}{16}$ " U.H.)	5	5	-	-
8	F4717	Nut	5	5	-	-
9	F4483	Self-tapping screw	5	5	-	-
10	F4680	Clip	2	2	-	-
11	F2335	Bolt ($\frac{11}{16}$ " U.H.)	2	2	-	-
12	S26-3	Spring washer	2	2	-	-
13	S1-51	Nut	2	2	-	-
14	F4686	Number plate	1	1	-	-
15	F1369	Bolt ($\frac{5}{8}$ " U.H.)	2	2	-	-
16	S26-2	Spring washer	2	2	-	-
17	F879	Nut	2	2	-	-
18	F3098	Vent pipe clip	1	1	-	-
19	F4239	TWINSEAT	1	1	-	-
19	F4691	TWINSEAT c/w BRACKETS	-	-	1	1
20	F4244	Twinseat cover c/w clips	1	1	1	1
21	F4475	Clip		as required		
22	F4222	Hinge	2	2	-	-
23	DS57	Bolt ($\frac{7}{16}$ " U.H.)	4	4	-	-
24	S26-2	Spring washer	4	4	-	-
25	D374	Check wire	1	1	-	-
26	F4226	Seat catch plunger	1	1	-	-
27	F4228	Spring	1	1	-	-
28	E1719A	Plain washer	1	1	-	-
29	$\frac{3}{32}$ " \times $\frac{1}{2}$ "	Split pin	1	1	-	-
30	F4227	Knob	1	1	-	-
31	F4361	Safety strap	A	A	A	A
32	F4365	Self-tapping screw	4	4	4	4

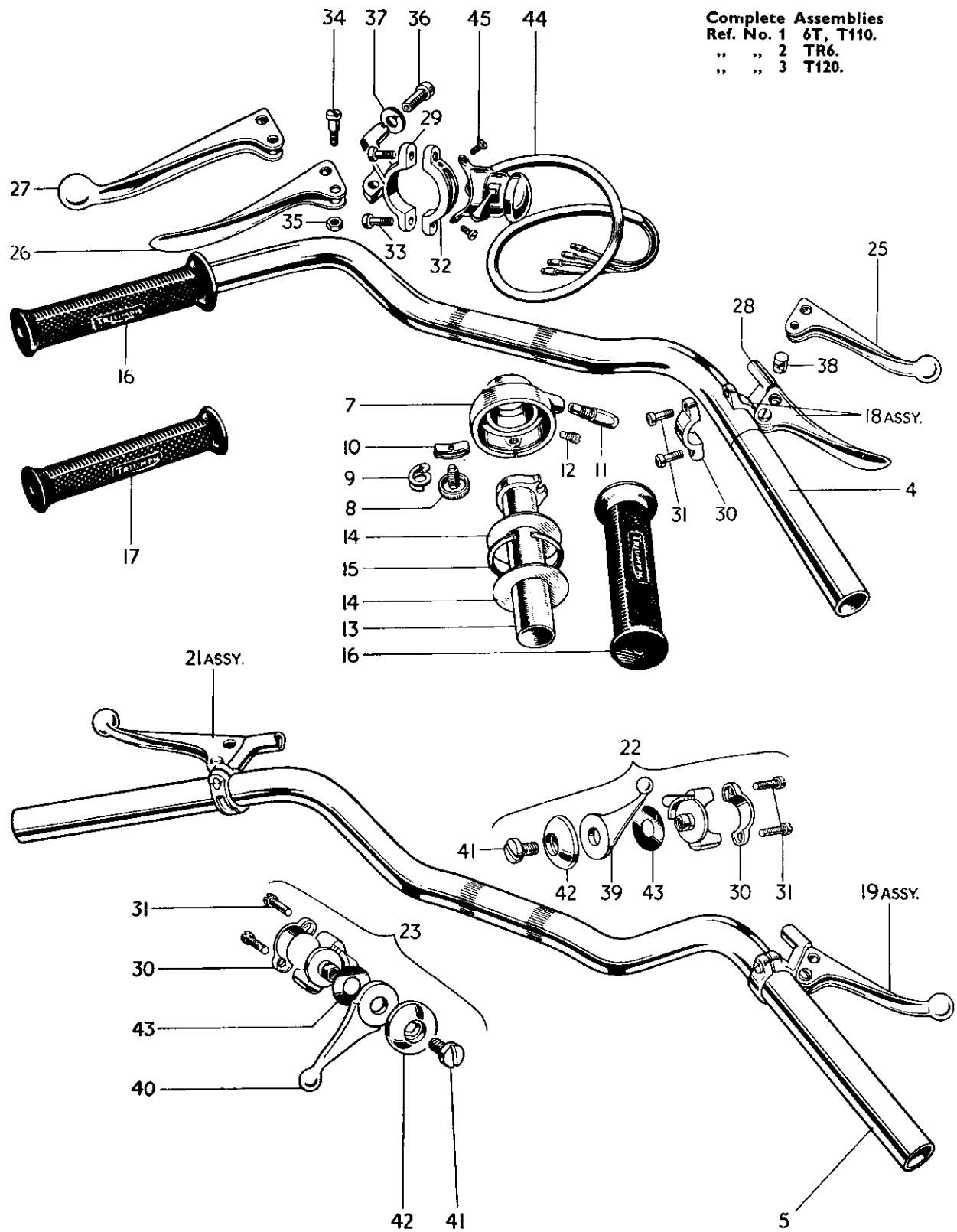

FIG. 28 HANDLEBARS

HANDLEBARS

			6T	T110	TR6	T120
1	H1223	HANDLEBAR c/w CONTROLS	1	1	-	-
2	H1224	HANDLEBAR c/w CONTROLS	-	-	1	-
3	H1313	HANDLEBAR c/w CONTROLS	-	-	-	1
4	H1009	Handlebar	1	1	-	-
4	H811	Handlebar	-	-	-	1
5	H1003	Handlebar	-	-	1	-
6	H697	TWISTGRIP ASSEMBLY	1	1	1	1
7	H698	Twistgrip head assembly (Nos. 8-12)	1	1	1	1
8	H665	Friction screw	1	1	1	1
9	H685	Spring	1	1	1	1
10	H686	Friction spring	1	1	1	1
11	H234	Cable thimble	1	1	1	1
12	H237	Grub screw	1	1	1	1
13	H700	Sleeve	1	1	1	1
14	H233	Retaining plate	2	2	2	2
15	H232	Circlip	1	1	1	1
16	H230	Rubber grip (and at left handlebar)	2	2	2	1
17	H230A	Left rubber grip	-	-	-	1
18	18/886	FRONT BRAKE LEVER ASSEMBLY	1	1	-	-
19	18/908	FRONT BRAKE LEVER ASSEMBLY (Ball-end)	-	-	1	1
20	18/894	CLUTCH LEVER ASSEMBLY	1	1	-	-
21	18/909	CLUTCH LEVER ASSEMBLY (Ball-end)	-	-	1	1
22	12/614	AIR LEVER ASSEMBLY	-	-	1	-
23	12/613	MAGNETO LEVER ASSEMBLY	-	-	1	-
24	18/535	Brake lever	1	1	-	-
25	18/754	Brake lever (Ball-end)	-	-	1	1
26	18/528	Clutch lever	1	1	-	-
27	18/752	Clutch lever (Ball-end)	-	-	1	1
28	18/890	Brake lever bracket	1	1	1	1
29	18/892	Clutch lever bracket	1	1	1	1
30	12/044	Clamp	1	1	3	1
31	11/014	Screw	2	2	6	2
32	H668	Clamp	1	1	1	1
33	61/004	Screw	2	2	2	2
34	18/087	Fulcrum screw	2	2	2	2
35	18/053	Self-locking nut	2	2	2	2
36	18/838	Cable adjuster	2	2	2	2
37	18/839	Thumb nut	2	2	2	2
38	18/880	Barrel nipple	2	2	2	2
39	12/556	Air lever	-	-	1	-
40	12/014	Magneto lever	-	-	1	-
41	12/607	Centre bolt	-	-	2	-
42	12/606	Cap	-	-	2	-
43	12/033	Spring washer	-	-	2	-
44	31563	Horn push and dip switch	1	1	1	1
45	H689	Screw (½" U.H.)	2	2	2	2

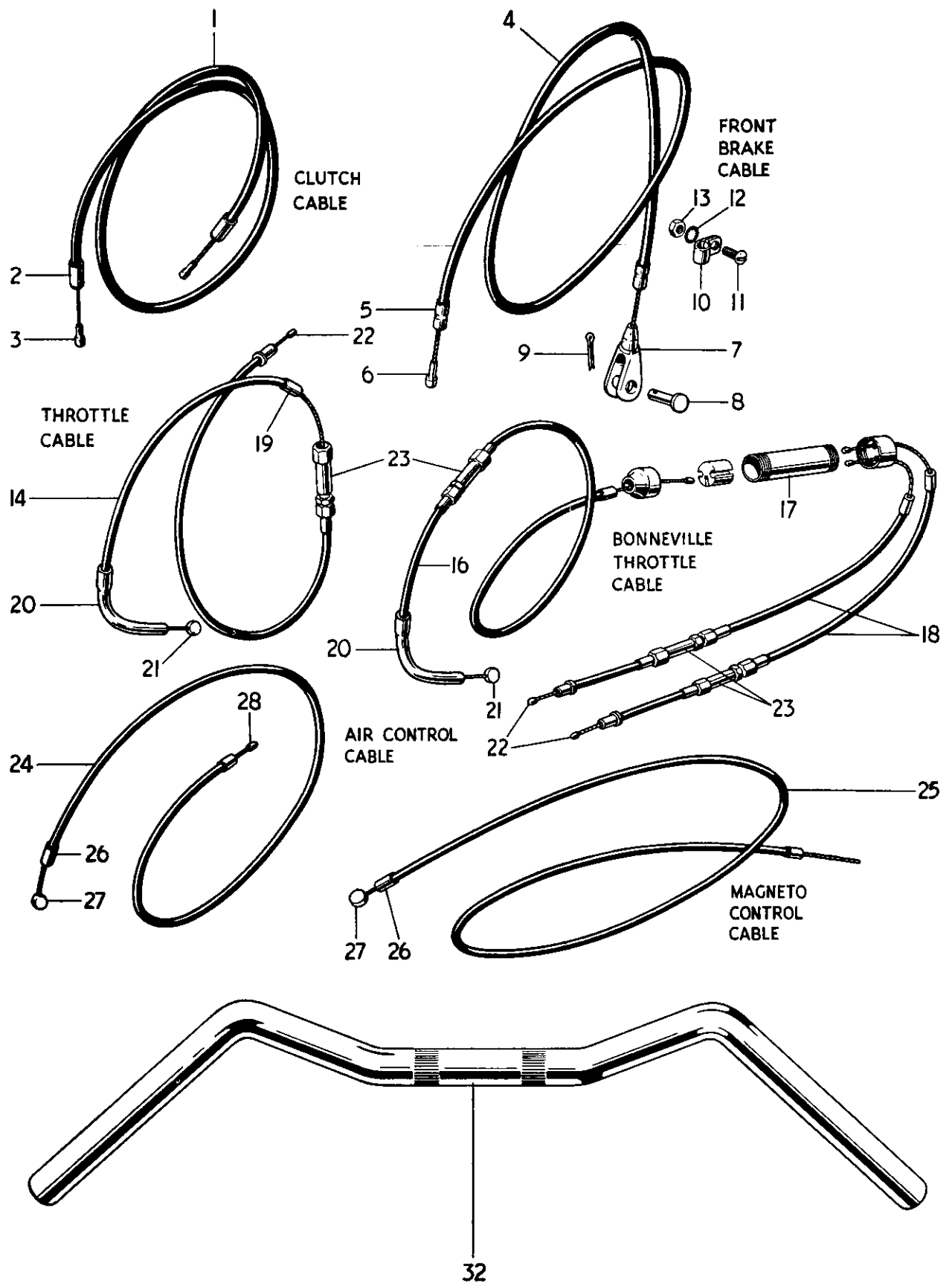

FIG. 29 CONTROL CABLES AND AMERICAN HANDLEBARS

CONTROL CABLES AND AMERICAN HANDLEBARS

									6T	T110	TR6	T120
1	D432	CLUTCH CABLE	1	1	1	1
2	D103	Ferrule	2	2	2	2
3	D368	Nipple	2	2	2	2
4	D414	FRONT BRAKE CABLE	1	-	-	-
4	D416	FRONT BRAKE CABLE	-	1	1	1
5	D103	Ferrule	2	2	2	2
6	D368	Nipple	1	1	1	1
7	W593	Fork end...	1	1	1	1
8	WF32	Pivot pin	1	1	1	1
9	$\frac{1}{16}'' \times \frac{3}{8}''$	Split pin	1	1	1	1
10	H1171	Clip	1	1	-	-
11	H916	Screw ($\frac{3}{32}''$ U.H.)	1	1	-	-
12	GS299	Serrated washer	1	1	-	-
13	H745	Nut	1	1	-	-
14	D224	THROTTLE CABLE	1	1	-	-
14	D439	THROTTLE CABLE	-	-	1	-
15	D421	THROTTLE CABLE	-	-	-	1
16	D422	Twistgrip cable	-	-	-	1
17	244/104	Junction box	-	-	-	1
18	D423	Carburetter cable	-	-	-	2
19	D101	Ferrule	3	3	3	10
20	H670	Guide tube	1	1	1	1
21	D83	Nipple	1	1	1	1
22	NS191	Nipple	1	1	1	5
23	D104	Adjuster	1	1	1	3
24	D435	AIR CONTROL CABLE	-	-	1	-
25	D100	MAGNETO CONTROL CABLE	-	-	1	-
26	D101	Ferrule	-	-	4	-
27	D83	Nipple	-	-	2	-
28	NS191	Nipple	-	-	1	-
		Magneto cable end fittings supplied with magneto										
29	H1246	AMERICAN HANDLEBAR c/w CONTROLS	1	1	-	-
30	H1228	AMERICAN HANDLEBAR c/w CONTROLS	-	-	1	-
31	H1314	AMERICAN HANDLEBAR c/w CONTROLS	-	-	-	1
32	H1247	American handlebar	1	1	-	-
33	H1179	American handlebar	-	-	1	1
34	D434	Clutch cable	1	1	1	1
35	D415	Front brake cable	1	-	-	-
35	D417	Front brake cable	-	1	1	1
36	D257	Throttle cable	1	1	-	-
36	D440	Throttle cable	-	-	1	-
37	D424	THROTTLE CABLE	-	-	-	1
38	D425	Twistgrip cable	-	-	-	1
39	D260	Magneto control cable	-	-	1	-

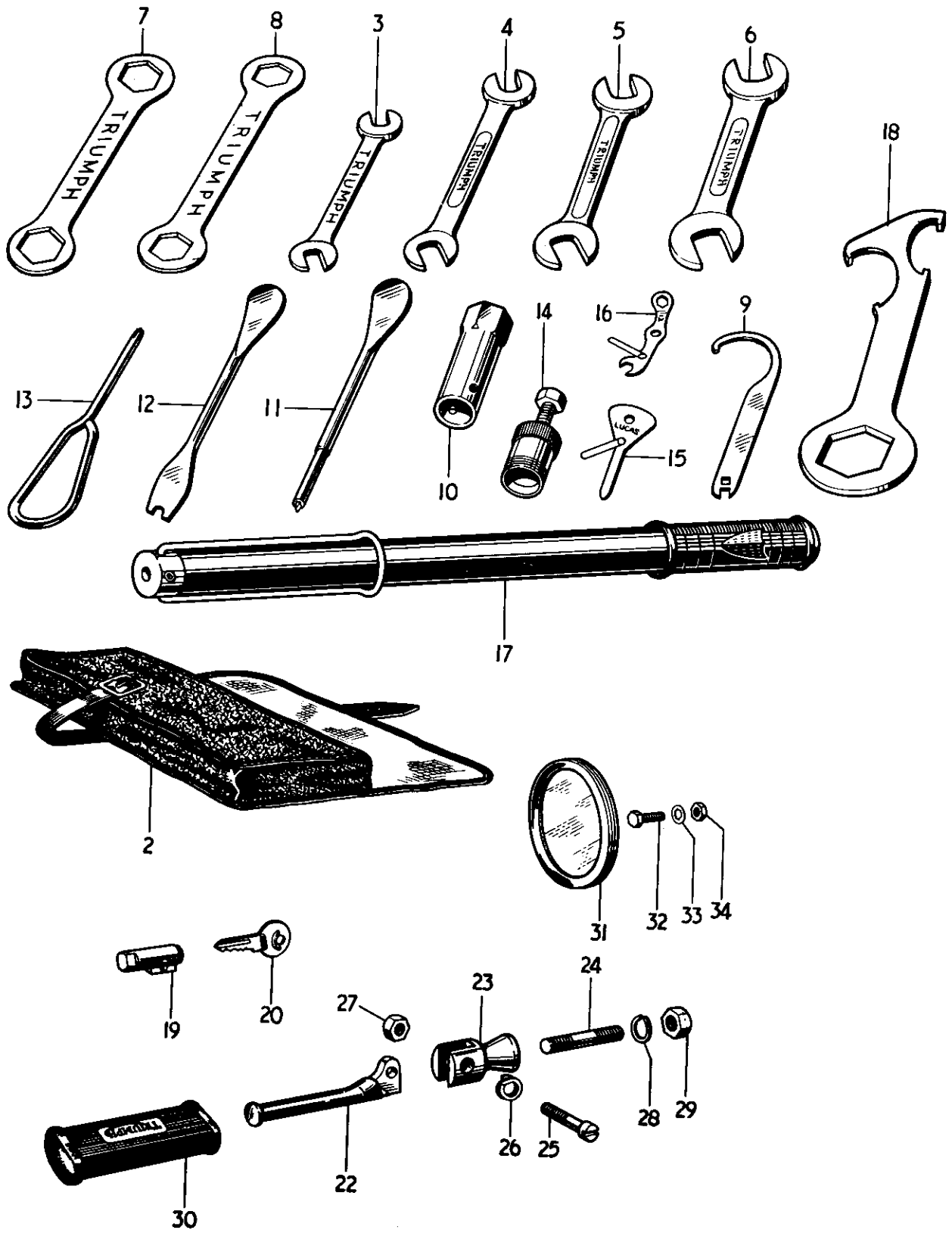

FIG. 30 TOOL KIT, FRAME LOCK, PILLION FOOTREST AND LICENCE HOLDER

TOOLKIT, FRAME LOCK, PILLION FOOTRESTS AND LICENCE HOLDER

									6T	T110	TR6	T120
1	D365	TOOLKIT COMPLETE	1	1	1	1
2	WA58	Tool roll	1	1	1	1
3	D360	Open spanner, $\frac{1}{8}$ " \times $\frac{5}{16}$ " Whit.	1	1	1	1
4	D361	Open spanner, $\frac{3}{16}$ " \times $\frac{1}{4}$ " Whit.	1	1	1	1
5	NA55	Open spanner, $\frac{1}{4}$ " \times $\frac{5}{16}$ " Whit.	1	1	1	1
6	DA16	Open spanner, $\frac{3}{8}$ " \times $\frac{7}{16}$ " Whit.	1	1	1	1
7	PA57	Ring spanner, $\frac{1}{2}$ " \times $\frac{9}{16}$ " Whit.	1	1	1	1
8	D311	Ring spanner, $\frac{5}{8}$ " \times $\frac{11}{16}$ " Whit.	1	1	1	1
9	D362	"C" Spanner and Tappet Key	1	1	1	1
10	D87	Plug spanner	1	1	1	1
11	D363	Tyre lever and screwdriver	1	1	1	1
12	D364	Tyre lever and clutch key	1	1	1	1
13	D336	Phillips No. 3 Screwdriver	1	1	1	1
14	DA50/1	Clutch Hub extractor	1	1	1	1
15	400935	Screwdriver	1	-	-	-
16	415116	Spanner	-	1	1	1
17	D296	Tyre inflator	1	1	1	1
18	D220	Fork spanner	A	A	A	A
19	D402/3	FRAME LOCK c/w KEYS	1	1	1	1
20	D403	Key (state number)	1	1	1	1
21	F4327	PILLION FOOTREST	2	2	2	2
22	F1694	Pedal	2	2	2	2
23	F2268	Hanger	2	2	2	2
24	F4309	Stud ($1\frac{3}{8}$ " O.A.)	2	2	2	2
25	F2271	Pivot bolt	2	2	2	2
26	F2277	Thackeray (Spring) Washer	2	2	2	2
27	S1-51	Nut	2	2	2	2
28	S26-1	Spring washer	2	2	2	2
29	S1-52	Nut	2	2	2	2
30	F1695	Pedal rubber	2	2	2	2
31	D261	Licence holder	1	1	1	1
32	DS57	Bolt ($\frac{7}{16}$ " U.H.)	1	1	-	-
33	E1612	Serrated washer	1	1	-	-
34	F879	Nut	1	1	-	-

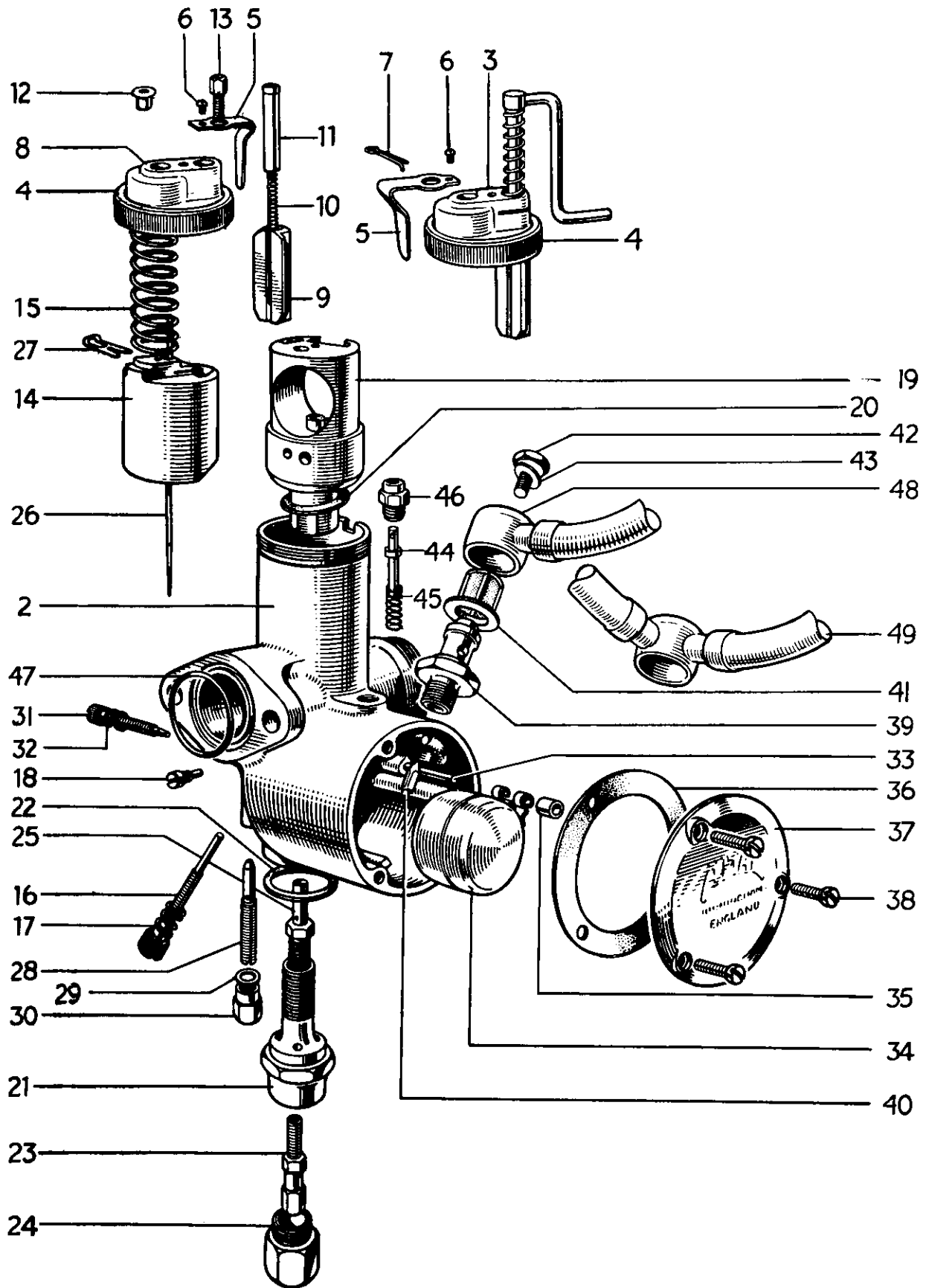

FIG 31 CARBURETTER, 6T, T110 AND TR6

CARBURETTER 6T, T110 AND TR6

			6T	T110	TR6
1	376/256	CARBURETTER	1	-	-
1	376/255	CARBURETTER	-	1	-
1	376/40	CARBURETTER	-	-	1
2	376/003	Mixing chamber 1 1/8" choke	1	1	1
3	376/174	AIR VALVE ASSEMBLY	1	1	-
4	376/065	Mixing chamber cap	1	1	1
5	29/307	Spring	1	1	-
5	4/276	Spring	-	-	1
6	4/241	Screw	1	1	1
7	30/064	Spring	1	1	-
8	376/107	Mixing chamber top	-	-	1
9	376/062	Air valve	-	-	1
10	4/046	Spring	-	-	1
11	6/047	Air valve guide	-	-	1
12	6/132A	Throttle cable ferrule	1	1	1
13	4/035	Air cable adjuster	-	-	1
14	376/060	Throttle valve (3/2 cutaway)	1	1	1
15	376/061	Throttle return spring	1	1	1
16	376/068	Throttle stop screw	1	1	1
17	376/069	Stop screw spring	1	1	1
18	376/070	Peg screw	1	1	1
19	376/057	Jet block (1 1/8" choke)	1	1	1
20	376/067	Joint washer	1	1	1
21	376/073	Jet holder	1	1	1
22	376/074	Fibre washer	1	1	1
23	376/100	Main jet 270	1	-	-
23	376/100	Main jet 250	-	1	1
24	376/075	Cover nut	1	1	1
25	376/072	Needle jet (-1065)	1	1	1
26	376/063	Needle (Type C)	1	1	1
27	4/230	Needle clip	1	1	1
28	376/076	Pilot jet (25)	1	1	1
29	116/162	Fibre washer	1	1	1
30	376/095	Cover nut	1	1	1
31	332/017	Air adjusting screw	1	1	1
32	4/148	Spring	1	1	1
33	376/085	Float spindle	1	1	1
34	376/083	Float	1	1	1
35	376/094	Bush	1	1	1
36	376/078	Joint washer	1	1	1
37	376/077	Cover	1	1	1
38	376/079	Screw	3	3	3
39	376/088	Needle seating	1	1	1
40	376/089	Needle	1	1	1
41	376/093	Filter	1	1	1
42	376/091	Bolt	1	1	1
43	376/092	Fibre washer	1	1	1
44	376/086	Tickler	1	1	1
45	376/087	Tickler spring	1	1	1
46	343/011	Tickler body	1	1	1
47	244/1048	"O" ring seal	1	1	1
48	F4448	Petrol pipe assembly	1	-	-
49	F4720	Petrol pipe assembly	-	1	1

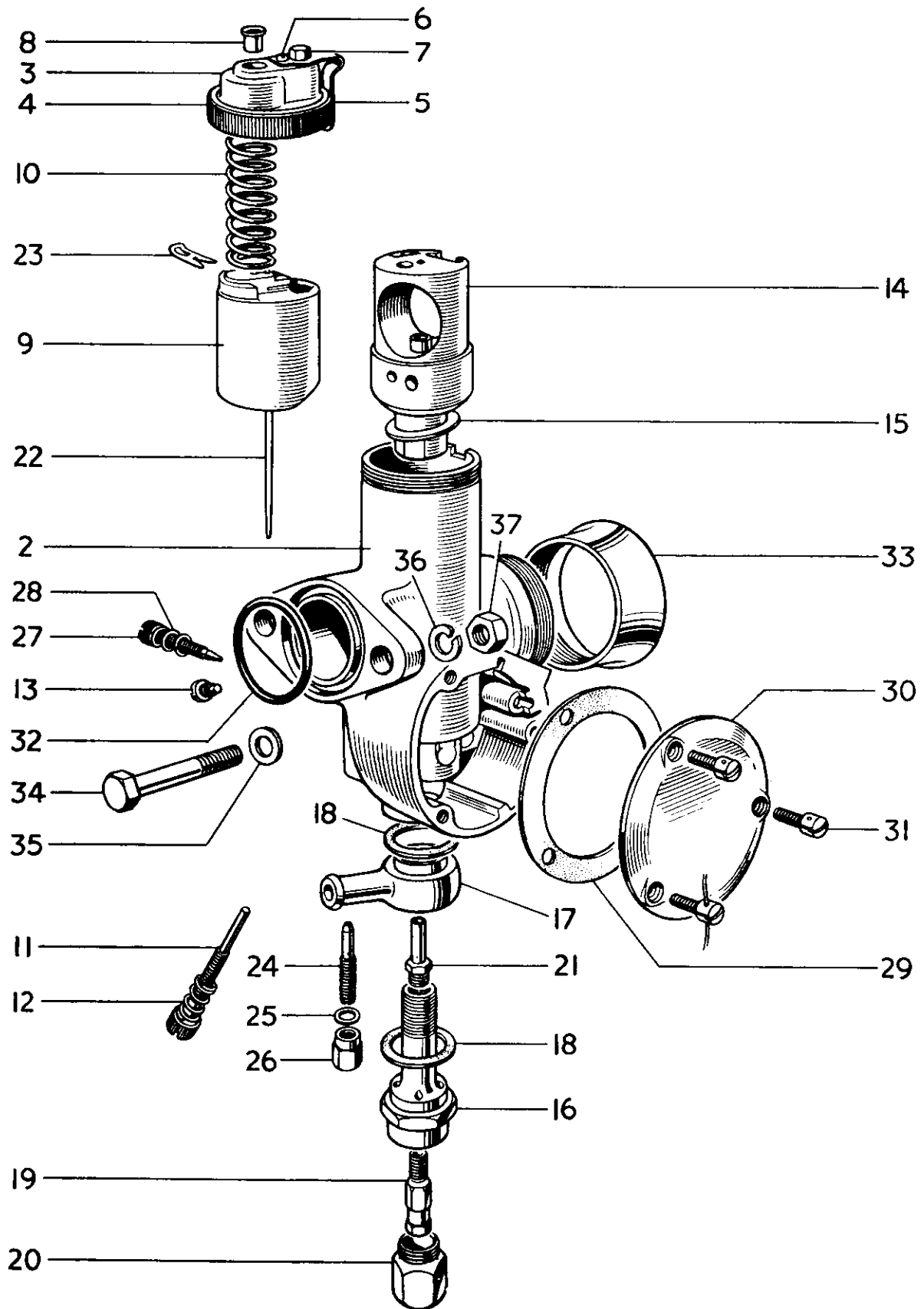

FIG. 32 BONNEVILLE 120 CARBURETTERS

BONNEVILLE 120 CARBURETTERS

T120

Ref. No.	Part No.	DESCRIPTION	QUANTITY
1	376/233	MIXING CHAMBER ASSEMBLY	2
2	376/164	Mixing chamber (1 $\frac{1}{8}$ " choke)	2
3	376/107	Mixing chamber top	2
4	376/065	Mixing chamber cap	2
5	4/276	Spring	2
6	4/241	Screw	2
7	4/137A	Plug screw	2
8	6/132A	Throttle cable ferrule	2
9	376/060	Throttle valve (3 $\frac{1}{2}$ cutaway)	2
10	376/132	Throttle return spring (light)	2
11	376/068	Throttle stop screw	2
12	376/069	Stop screw spring	2
13	376/070	Peg screw	2
14	376/057	Jet block (1 $\frac{1}{8}$ " choke)	2
15	376/067	Joint washer	2
16	376/140	Jet holder	2
17	376/141	Inlet banjo	2
18	376/074	Fibre washer	4
19	376/100	Main jet (240)	2
20	376/075	Cover nut	2
21	376/072	Needle jet (-1065)	2
22	376/063	Needle (Type C)	2
23	4/230	Needle clip	2
24	376/076	Pilot jet (25)	2
25	116/162	Fibre washer	2
26	376/095	Cover nut	2
27	332/017	Air adjusting screw	2
28	4/148	Spring	2
29	376/078	Joint washer	2
30	376/077	Cover	2
31	376/151	Screw	6
32	244/1048	"O" ring seal	2
33	376/066	Air intake tube	2
34	F2603	Bolt ($\frac{1}{8}$ " U.H.)	4
35	S25-3	Plain washer	4
36	S26-3	Spring washer	4
37	S1-51	Nut	4

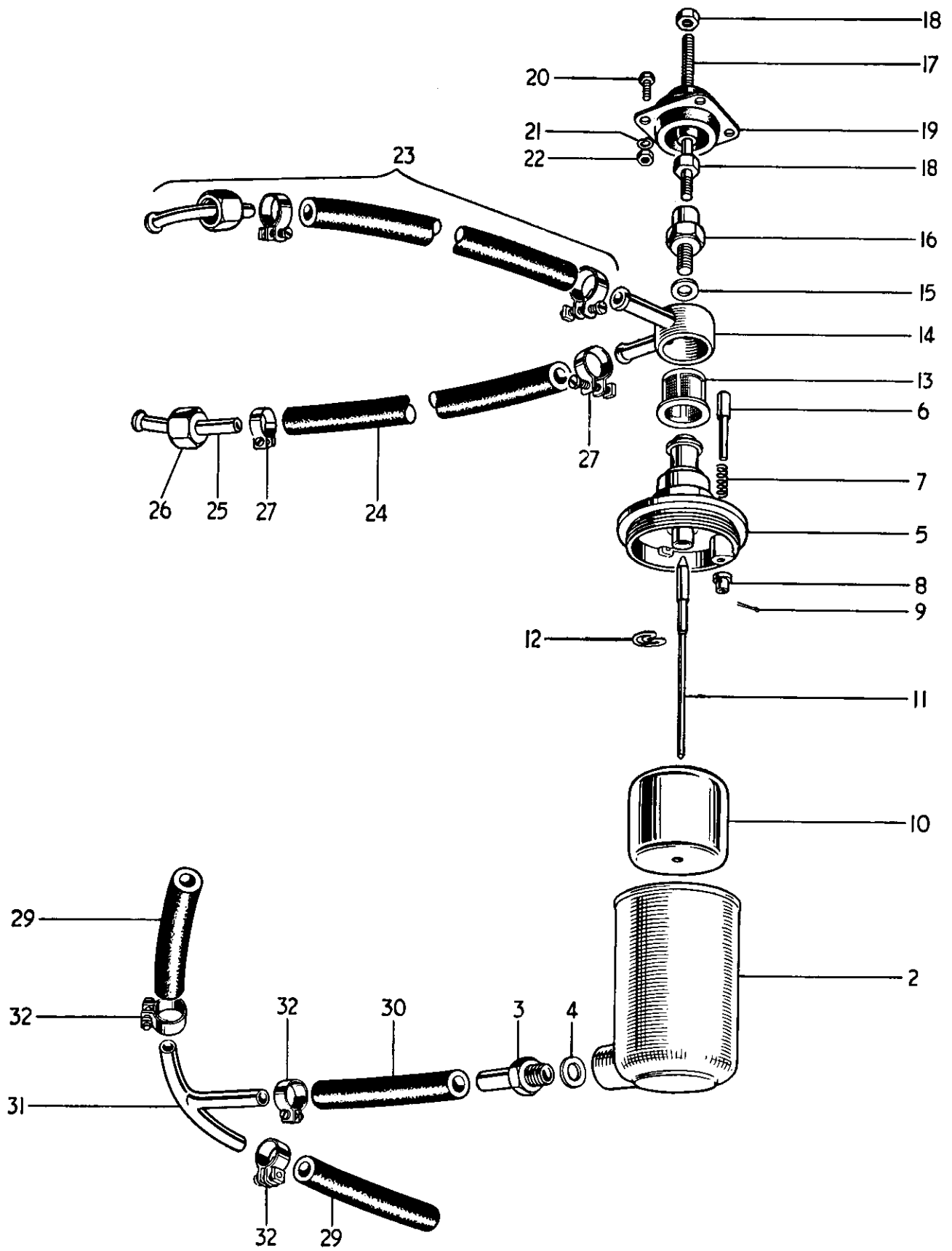

FIG. 33 BONNEVILLE 120 FLOAT CHAMBER

BONNEVILLE 120 FLOAT CHAMBER

T120

Ref. No.	Part No.	DESCRIPTION	QUANTITY
1	14/624	FLOAT CHAMBER	1
2	14/363	Float chamber	1
3	14/219	Inlet union	1
4	14/336	Fibre washer	1
5	14/385	COVER c/w TICKLER	1
6	14/209	Tickler	1
7	14/032	Spring	1
8	14/210	Stop	1
9	14/289	Split pin	1
10	14/017	Float	1
11	14/355	Needle	1
12	161/054	Clip	1
13	376/093	Filter	1
14	376/135	Banjo	1
15	376/092	Fibre washer	1
16	14/384	Bolt	1
17	14/383	Anchor stud	1
18	81/027	Nut	2
19	E3987	Flexible mounting	1
20	E4054	Screw ($\frac{5}{16}$ " U.H.)	2
21	E4053	Spring washer	2
22	T1017	Nut	2
23	F4722	PETROL PIPE	2
24	F4525	Rubber pipe	2
25	F3353	Obtuse elbow	2
26	F3337	Union nut	2
27	E4035	Clip	4
28	F4725	PETROL PIPE	1
29	F4726	Rubber pipe (long)	2
30	F4526	Rubber pipe (short)	1
31	F4356	"T" piece	1
32	E4035	Clip	6

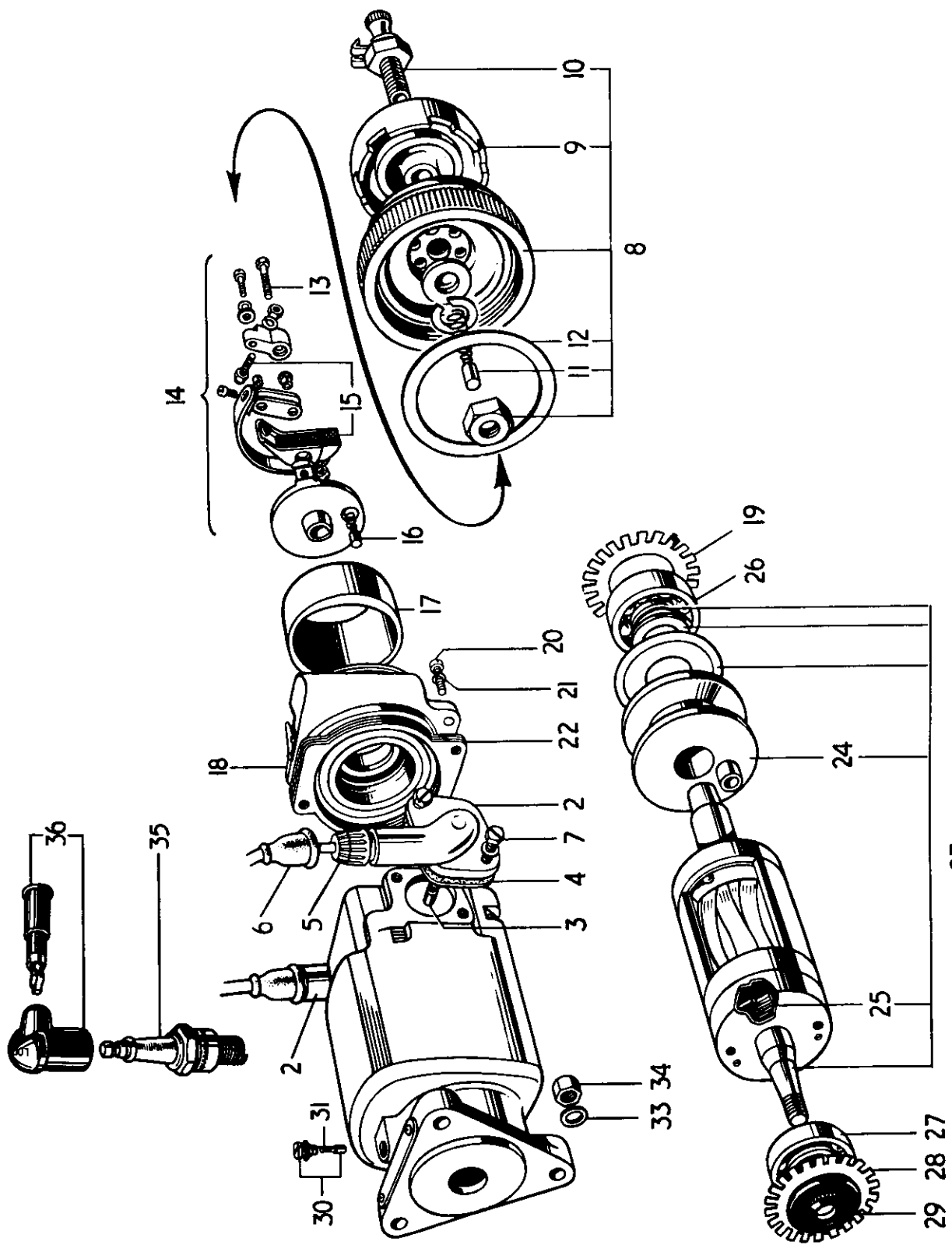

FIG. 34 MAGNETO WITH AUTOMATIC ADVANCE AND RETARD

MAGNETO WITH AUTOMATIC ADVANCE AND RETARD

			T110	TR6	T120
1	42344	MAGNETO	1	-	1
2	458876	PICK-UP	2	-	2
3	451260	Brush and spring	2	-	2
4	458877	Joint washer	2	-	2
5	410600	Moulded nut	2	-	2
6	458658	Rubber grommet	2	-	2
7	145074	Fixing screw	4	-	4
8	459269	CONTACT BREAKER COVER	1	-	1
9	459266	Moulded breather cap	1	-	1
10	459888	Terminal assembly	1	-	1
11	455190	Brush and spring	1	-	1
12	457681	Rubber washer	1	-	1
13	492856	Contact breaker screw	1	-	1
14	492854	CONTACT BREAKER	1	-	1
15	54440888	Contact and spring set	1	-	1
16	470537	Earthing brush and spring	1	-	1
17	459130	Cam	1	-	1
18	493716	End plate	1	-	1
19	463932	Insulating cup	1	-	1
20	150509	Screw	3	-	3
21	185048	Spring washer	3	-	3
22	452907	Shim (0.005")	as required		
23	459004	ARMATURE	1	-	1
24	455361	Slip ring	1	-	1
25	458339	Condenser	1	-	1
26	189294	Contact breaker end bearing	1	-	1
27	189244	Drive end bearing	1	-	1
28	459005	Drive bearing insulating cup	1	-	1
29	459002	Oil seal	1	-	1
30	455191	EARTH BRUSH, SPRING AND HOLDER	1	-	1
31	455190	Earth brush and spring	1	-	1
32	458675	Sundry parts set	1	-	1
33	S25-3	Plain washer	3	-	3
34	F1008	Nut	3	-	3

† Some early Magnetos 42344D were fitted with

122160	Contact breaker screw	} Interchangeable with the above as an assembly only.
470534	CONTACT BREAKER	
470609	Contact set	
470688	Spring set	

35		Sparking plug (Champion N3, K.L.N. F.E.100 or Lodge HLN)	2	2	2
36	D297	Plug cover and suppressor	2	2	2
36	D262	Plug cover	A	A	A

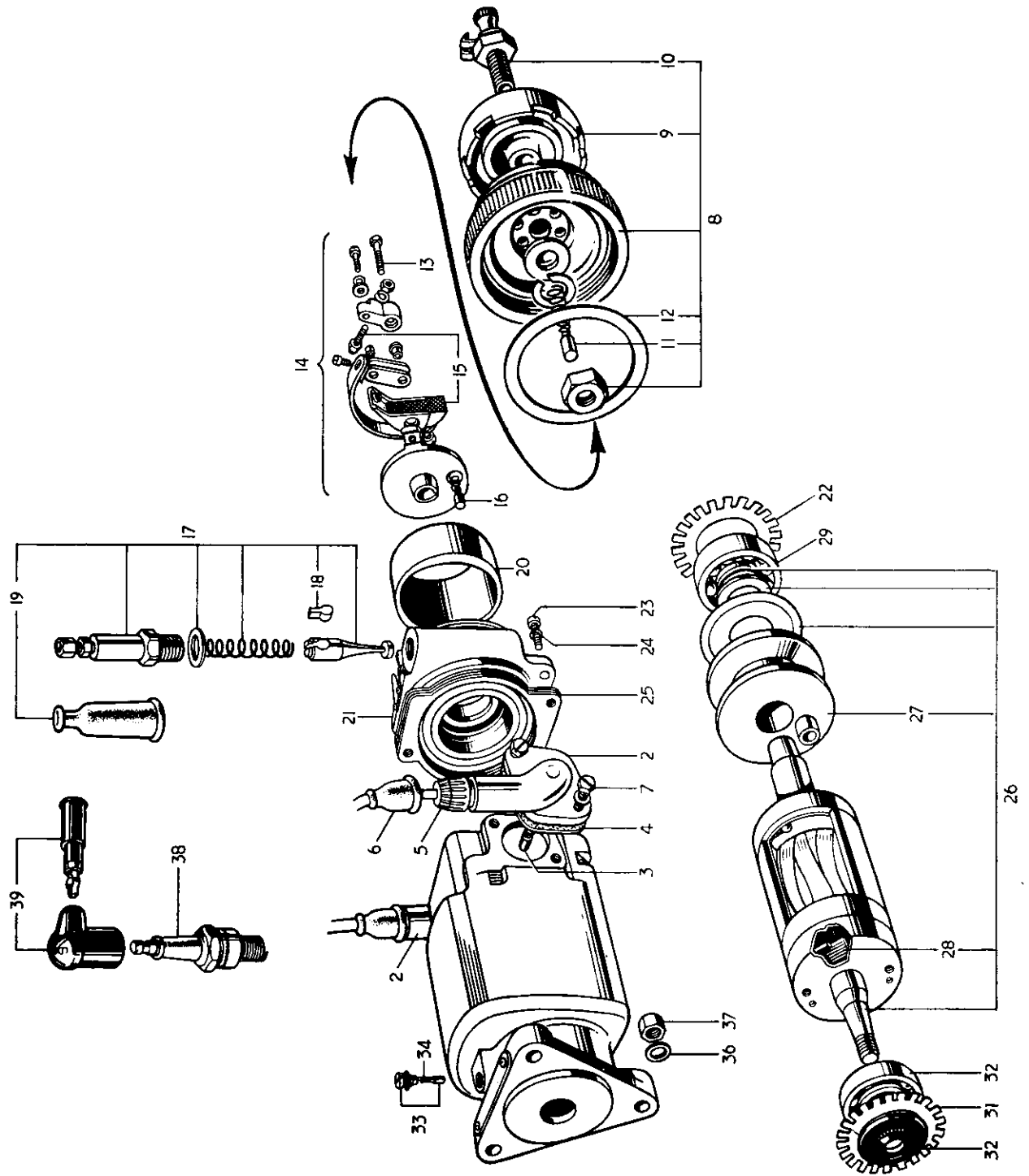

FIG. 35 MAGNETO WITH MANUAL CONTROL

MAGNETO WITH MANUAL CONTROL

										T110	TR6	T120
1	42298	MAGNETO	-	1	-
2	458876	PICK-UP	-	2	-
3	451260	Brush and spring	-	2	-
4	458877	Joint washer	-	2	-
5	410600	Moulded nut	-	2	-
6	458658	Rubber grommet	-	2	-
7	145074	Fixing screw	-	4	-
8	459269	CONTACT BREAKER COVER	-	1	-
9	459266	Moulded breather cap	-	1	-
10	459888	Terminal assembly	-	1	-
11	455190	Brush and spring	-	1	-
12	457681	Rubber washer	-	1	-
13	492856	Contact breaker screw	-	1	-
14	492854	CONTACT BREAKER	-	1	-
15	54440888	Contact and spring set	-	1	-
16	470537	Earthing brush and spring	-	1	-
17	492195	CONTROL PARTS SET	-	1	-
18	455788	Nipple	-	1	-
19	454475	Rubber cover	-	1	-
20	458725	Cam	-	1	-
21	459271	End plate	-	1	-
22	463932	Insulating cup	-	1	-
23	150509	Screw	-	3	-
24	185048	Spring washer	-	3	-
25	452907	Shim (0.005")	as required		
26	459004	ARMATURE	-	1	-
27	455361	Slip ring	-	1	-
28	458339	Condenser	-	1	-
29	189294	Contact breaker and bearing	-	1	-
30	189244	Drive end bearing	-	1	-
31	459005	Drive bearing insulating cup	-	1	-
32	459002	Oil seal	-	1	-
33	455191	EARTH BRUSH, SPRING AND HOLDER	-	1	-
34	455190	Earth brush and spring	-	1	-
35	458675	Sundry, parts set	-	1	-
36	S25-3	Plain washer	-	3	-
37	F1008	Nut	-	3	-
		† Some early magnetos 42298C were fitted with										
	122160	Contact breaker screw			
	470534	CONTACT BREAKER			
	470609	Contact set			
	470688	Spring set			
												Interchangeable with the above as an assembly only.
38		Sparking plug (Champion N3, K.L.G. F.E.100 or Lodge H.L.N.)	2	2	2
39	D297	Plug cover and suppressor	2	2	2
39	D262	Plug cover	A	A	A

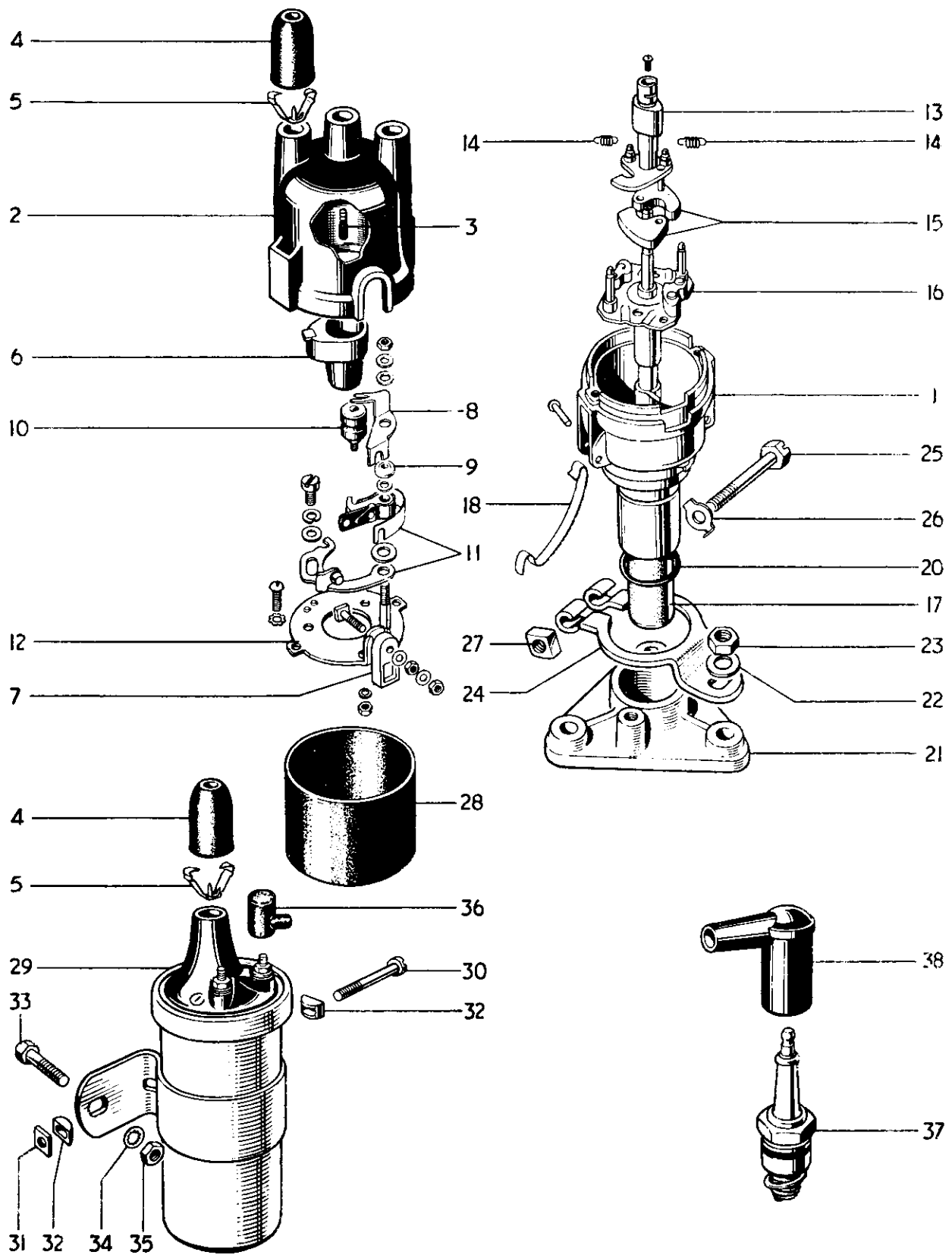

FIG. 36 DISTRIBUTOR AND COIL

DISTRIBUTOR AND COIL

Ref. No.	Part No.	DESCRIPTION	QUANTITY
1	40690	DISTRIBUTOR (Type 18D2)	1
2	425049	CAP ASSEMBLY	1
3	404435	Brush and spring	1
4	421554	Rubber grommet	4
5	421863	Cable clip	4
6	423486	Rotor	1
7	423110	Shaped insulating bush	1
8	423108	Condenser connector	1
9	423109	Insulating bush	1
10	54410823	Condenser	1
11	425219	Contact set	1
12	423113	Base plate	1
13	425284	Cam	1
14	425398	Spring set	1
15	421056	Weight set	1
16	425444	Shaft and action plate	1
17	425498	Bearing bush	1
18	424158	Retaining clip	2
19	425243	Sundry parts set	1
20	188639	Rubber "O" ring	1
21	E3122	Distributor adaptor	1
22	S25-3	Plain washer	3
23	S1-51	Nut	3
24	E4116	Clamping plate	1
25	112917	Clamp bolt	1
26	185051	Washer	1
27	173857	Nut	1
28	E4117	Distributor sheath	1
29	45077	Ignition coil (M.A.6)	1
30	100104	Clip screw	1
31	169160	Square nut	1
32	422369	"D" washer	2
33	DS57	Bolt ($\frac{7}{16}$ " U.H.)	2
34	E1612	Serrated washer	2
35	F879	Nut	2
36	236741	Rubber cover	2
37		Sparking plug (Champion L7, K.L.G. F.80 or Lodge H.14)	2
38	D297	Plug cover and suppressor	2
38	D262	Plug cover	A

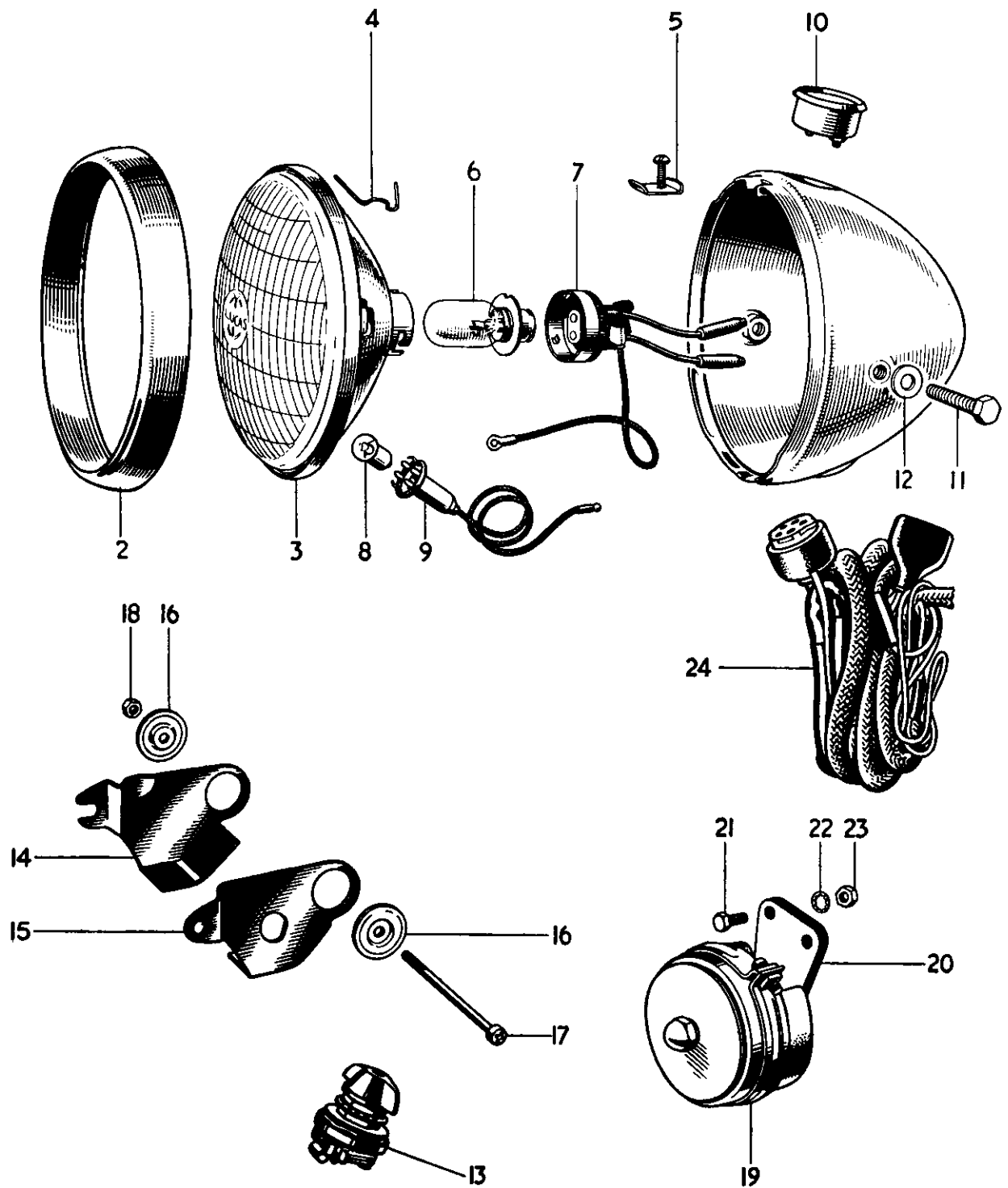

FIG. 37 HEADLAMP AND WIRING HARNESS, TR6 AND T120

HEADLAMP AND WIRING HARNESS, TR6 AND T120

											TR6	T120
1	58556	HEADLAMP COMPLETE	1	1
2	553248	Rim	1	1
3	516798	Light unit	1	1
4	504665	Fixing wire	6	6
5	534296	Screw and plate	1	1
6	312	Bulb (30/24W. Vert. dip, Pre-focus)	1	1
7	554602	Adaptor	1	1
8	988	Bulb (3W. M.C.C.)	1	1
9	554710	Pilot bulbholder	1	1
10	36084	Ammeter	1	1
11	112201	Bolt	2	2
12	137141	Plain washer	2	2
13	31784	Lighting switch (SA.41)	1	1
14	F4696	Left switch bracket	1	1
15	F4697	Right switch bracket	1	1
16	E3798	Cap	2	2
17	E3221	Screw (1 $\frac{1}{8}$ " U.H.)	1	1
18	H745	Nut	1	1
19	70048	Horn	1	1
20	701851	Fixing plate	4	4
21	F4771	Bolt ($\frac{1}{2}$ " U.H.)	2	2
22	GS299	Serrated washer	2	2
23	H745	Nut	2	2
24	54944995	Wiring harness	1	1

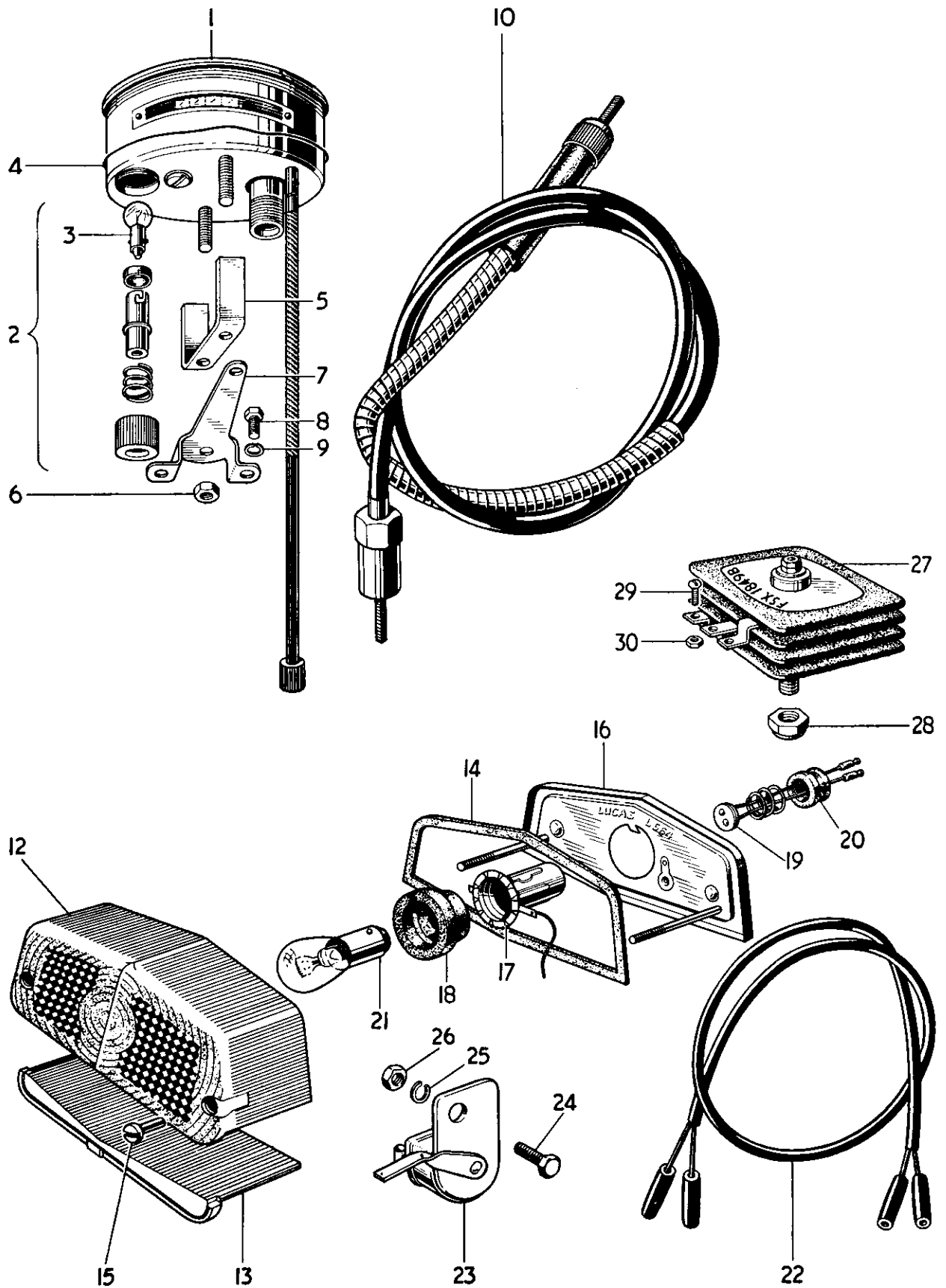

FIG. 38 SPEEDOMETER, TAIL LAMP AND RECTIFIER

SPEEDOMETER, TAIL LAMP AND RECTIFIER

								6T	T110	TR6	T120
1	SC3304/19	Speedometer head (125 m.p.h.)	1	1	-	-
1	SC3304/20	Speedometer head (190 k.p.h.)	1	1	-	-
1	SC5301/09	Speedometer head (125 m.p.h.)	-	-	1	1
1	SC5301/16	Speedometer head (190 k.p.h.)	-	-	1	-
1	SC5301/18	Speedometer head (240 k.p.h.)	-	-	-	1
2	P53279/1	BULB HOLDER c/w BULB	1	1	1	1
3	P52305	Bulb	1	1	1	1
4	P22469	Rubber ring	1	1	-	-
5	25578/2	Clamp bar	1	1	-	-
6	N1253	Nut	2	2	2	2
7	DS40	Bracket	-	-	1	1
8	DS57	Bolt ($\frac{7}{16}$ " U.H.)	-	-	2	2
9	S26-2	Spring washer	-	-	2	2
10	D245	Speedometer drive cable (44" long)	1	1	-	-
10	D245A	Speedometer drive cable (44" long)	-	-	1	1
11	53432	STOP AND TAIL LAMP (Type 564)	1	1	1	1
12	573839	Lens	1	1	1	1
13	575200	Window	1	1	1	1
14	575208	Lens seating gasket	1	1	1	1
15	575219	Sleeve nut	2	2	2	2
16	576002	Base assembly	1	1	1	1
17	575209	Bulbholder	1	1	1	1
18	575207	Grommet	1	1	1	1
19	573828	Contact Assembly	1	1	1	1
20	573825	Grommet	1	1	1	1
21	384	Bulb (6/18W. Offset pin.)	1	1	1	1
22	838604	Stop and tail lamp lead	1	1	1	1
23	34279	Stop lamp switch (6SA)	1	1	1	1
24	F929	Bolt ($\frac{1}{2}$ " U.H.)	1	1	1	1
25	S26-3	Spring washer	1	1	1	1
26	S1-51	Nut	1	1	1	1
27	47132	Rectifier	1	1	1	1
28	F3600	Self-locking nut	1	1	1	1
29	F4813	Screw ($\frac{5}{16}$ " U.H.)	3	3	3	3
30	H919	Nut	3	3	3	3



SUPPLEMENT TO
REPLACEMENT
PARTS
CATALOGUE No. 16

NEW SEASONS MODELS

6T - THUNDERBIRD

T110 - TIGER 110

TR6 R and C - TROPHY

T120 R and C - BONNEVILLE 120

From Engine No. D 7727 onwards

September, 1960

				6T	T110	TR6		T120	
						R	C	R	C
Page 17									
14	CP159	PISTON COMPLETE 7.5 : 1 C.R.	... Stock	2	-	-	-	-	-
14	CP157	PISTON COMPLETE 8.5 : 1 C.R.	... Stock	-	2	2	2	2	2
21	E3108/22	Engine Sprocket Stock	1	1	-	-	-	-
21	E3108/21	Engine Sprocket Stock	-	-	1	1	1	1
37	E3325	Inlet Camshaft Stock	1	1	-	-	-	-
38	E3325	Exhaust Camshaft Stock	1	1	1	1	1	1

Page 21

13	E4191	OIL RELEASE VALVE AND INDICATOR							
			Replaces E2795	1	1	1	1	1	1
16	E4192	Cap	Replaces E2790	1	1	1	1	1	1
—	E4193	Sealing ring	NEW	1	1	1	1	1	1
—	E4194	Cup	NEW	1	1	1	1	1	1
24	E2973	Stud ($1\frac{1}{8}$ in. O.A.)	Stock	4	4	4	4	-	-
29	E2962	Stud ($1\frac{7}{32}$ in. O.A.)	Stock	2	2	2	2	-	-
30	NA43A	Joint Washer	Stock	1	1	1	1	-	-
31	E2968	Insulating block	Stock	1	1	1	1	-	-

Page 23. For 6T read as for T110 on page 25.

Page 29

1	T1528	GEARBOX COMPLETE — STANDARD RATIO							
			Replaces T1525	1	1	-	-	-	-
1	T1583	GEARBOX COMPLETE — STANDARD RATIO	Stock	-	-	1	1	1	1
2	T1605	GEARBOX CASING	NEW	1	1	1	1	1	1
5	T1606	Layshaft bearing	NEW	1	1	1	1	1	1
—	T1607	Thrust washer	NEW	1	1	1	1	1	1
10	T1612	GEARBOX INNER COVER	NEW	1	1	1	1	1	1
11	T1614	Layshaft bearing	NEW	1	1	1	1	1	1
—	T1607	Thrust washer	NEW	1	1	1	1	1	1

Page 31

11	T1608	LAYSHAFT COMPLETE (20T)	NEW	1	1	1	1	1	1
11	T1610	LAYSHAFT COMPLETE (18T)	NEW	A	A	A	A	A	A
11	T1609	Layshaft c/w high gear (22T)	NEW	A	A	A	A	A	A

Page 33

29	T1270	FOLDING KICKSTARTER	Stock	1	1	1	1	1	1
40	T402	Clutch operating arm	Stock	-	-	1	1	1	1

				6T	T110	TR6		T120		
						R	C	R	C	
Page 41										
20	F4569	Flanged nut	NEW	1	1	1	1
—	F4746	Eyebolt	NEW	1	1	1	1
24	GS203	Plain washer	Stock	4	4	4	4
25	E1310	Nut	Stock	4	4	4	4
26	F4669	Abutment pin	Stock	2	2	2	2
27	S26-3	Spring washer	Stock	2	2	2	2
28	S1-51	Nut	Stock	2	2	2	2

Page 43										
12	47178	Stator	Replaces 47134	—	1	1	1

Page 45										
—	E4177	Left exhaust pipe	NEW	—	—	1	—
—	E4179	Right exhaust pipe	NEW	—	—	1	—
—	E2989	Left Bracket	Stock	—	—	1	—
—	E2990	Right bracket	Stock	—	—	1	—
—	E4181	Extended nut	NEW	—	—	1	—
—	S26-1	Spring washer	Stock	—	—	1	—
—	W840	Bolt ($1\frac{7}{8}$ in. U.H.)	Stock	—	—	1	—
—	E4204	Exhaust leg guard	Replaces E4032	—	—	2	—
—	E4207	Clip	NEW	—	—	4	—
—	F4715	Screw ($1\frac{3}{8}$ in. U.H.)	Stock	—	—	4	—
—	E2351	Plain washer	Stock	—	—	4	—
—	F3799	Nut	Stock	—	—	4	—
32	E4132	Left silencer	Stock	—	—	1	—
—	E4176	Right silencer	NEW	—	—	1	—
33	H622	Silencer hanger bolt ($1\frac{1}{8}$ in. U.H.)	Stock	—	—	2	—
34	F2694	Distance piece	Stock	—	—	2	—
35	S26-1	Spring washer	Stock	—	—	2	—
36	S1-52	Nut	Stock	—	—	2	—

Page 53. For 6T read as for T110 on page 55.

Page 55										
20	W1410	LEADING BRAKE SHOE	Replaces W1337	1	1	1	1
21	W1411	TRAILING BRAKE SHOE	Replaces W1338	1	1	1	1
22	W1414	Brake lining	NEW	1	1	1	1

Page 57. For T120 read as for TR6.

			6T	T110	TR6		T120		
					R	C	R	C	
Page 57									
23	W1406	LEADING BRAKE SHOE	} In pairs replace W93	...	1	1	1	1	1
23	W1407	TRAILING BRAKE SHOE		...	1	1	1	1	1

Page 59. For T120 read as for TR6.

Page 59

25	W1406	LEADING BRAKE SHOE	} In pairs replace W93	...	1	1	1	1	1
25	W1407	TRAILING BRAKE SHOE		...	1	1	1	1	1

Page 61. For T120 read as for TR6.

Page 61

35	F4893	Securing strap	...	Replaces F4655 and F4699	1	1	1	1	1
31	F3057	Petrol tap	1	1	1	2	2
32	F3116	Petrol tap with reserve tube	1	1	1	-	-

Page 77

1	376/255	Carburetter	1	1	-	-	-
1	376/257	Carburetter	-	-	-	2	2
49	F4720	Petrol pipe	1	1	1	-	-
—	F4841	Petrol pipe (short)	-	-	-	1	1
—	F4842	Petrol pipe (long)	-	-	-	1	1

Page 91

1	SC3304/24	Speedometer head (125 m.p.h.)							
			Replaces SC3304/19		1	1	-	-	-
1	SC3304/25	Speedometer head (190 k.p.h.)							
			Replaces SC3304/20		A	A	-	-	-
1	SC5301/09	Speedometer head (125 m.p.h.)	-	-	1	1	-
1	SC5301/16	Speedometer head (190 k.p.h.)	-	-	A	A	-
1	SC5301/26	Speedometer head (140 m.p.h.)	-	-	-	1	1
1	SC5301/18	Speedometer head (240 k.p.h.)	-	-	-	A	A
23	34181	Stop lamp switch	1	1	1	1	1
—	F4844	Crinkle washer (rectifier leads)	3	3	3	3	3

TRIUMPH

SUPPLEMENT TO
REPLACEMENT PARTS
CATALOGUE No. 16

FOR

6T — THUNDERBIRD

TR6 — TROPHY

T120 — BONNEVILLE 120

FROM ENGINE No. D15789 ONWARDS

SEPTEMBER 1961

TRIUMPH ENGINEERING CO. LTD., MERIDEN WORKS

ALLESLEY, COVENTRY, ENGLAND

1962 REPLACEMENT PARTS CATALOGUE

1962 Season's machines were basically as specified in the No. 16 Replacement Parts Catalogue for 1960/61 season's models, with the following amendments. These changes apply to machines from Engine No. D15789 except where otherwise stated.

Page 12

CARTON PACK LIST

CLOSE RATIO GEARS (To convert from Standard Ratio)
(Needle roller layshaft bearing condition — Engine No. D7727 onwards)

CP193	1	T1177	Mainshaft and low gear (18T)
	1	T1383	Mainshaft high gear (24T)
	1	T1179	Mainshaft third gear (23T)
	1	T955	Mainshaft second gear (21T)
	1	T1609	Layshaft c/w high gear (22T)
	1	T964	Layshaft third gear (23T)
	1	T963	Layshaft second gear (25T)
	1	T961	Layshaft low gear (28T)
	1	T1227	Blanking plug

Page 14

CARTON PACK LIST

VALVE SPRINGS

CP188	4	E4221	Inner valve spring (red)
	4	E4222	Outer valve spring (red)

6T (Engine No. D11193 onwards)

Page 17

CRANKSHAFT AND CONNECTING RODS

					6T	TR6	T120
E4492	CRANKSHAFT AND FLYWHEEL ASSEMBLY	1	1	1
E4493	Crankshaft c/w oil tube	1	1	1
E4479	Flywheel	1	1	1
CP159	PISTON COMPLETE 7.5 : 1 C.R. (D7727 onwards)	2	—	—
CP157	PISTON COMPLETE 8.5 : 1 C.R. (" ")	—	2	2
E3108/22	Engine sprocket	1	—	—
E3108/21	Engine sprocket	—	1	1
54213901	Rotor RM19	1	1	1
E4220	Camshaft (D11193 onwards)	2	—	—
E3134	Inlet camshaft	—	1	1
E1486R	Camwheel (3 keyway)	2	2	2

Page 21

OIL PUMP AND RELEASE VALVE AND MANIFOLD (D7727 onwards)

E4191	Oil release valve and indicator	1	1	1
E4192	Cap	1	1	1
E4193	Sealing ring	1	1	1
E4194	Cup	1	1	1
E2973	Stud (1 $\frac{5}{16}$ in. O.A.)	4	4	—
E2962	Stud (1 $\frac{7}{32}$ in. O.A.)	2	2	—
NA43A	Joint washer	1	1	—
E2968	Insulating block	1	1	—

Page 23

CYLINDER BLOCK AND HEAD 6T—Delete and read as for T110 and TR6 (on Page 25) with the following alterations. (D7727 onwards)

CYLINDER BLOCK AND HEAD T110 & TR6

						6T	TR6	T120
E4221	Valve spring inner (red) (D11193 onwards)	4	-	-
E4222	Valve spring outer (red) (D11193 onwards)	4	-	-
E3001	Valve spring inner (white)	-	4	-
E3002	Valve spring outer (white)	-	4	-

GEARBOX AND CASING (D7727 onwards)

T1583	GEARBOX COMPLETE — STANDARD RATIO	1	1	1
T1605	GEARBOX CASING	1	1	1
T1606	Layshaft bearing	1	1	1
T1607	Thrust washer	1	1	1
T1612	GEARBOX INNER COVER	1	1	1
T1614	Layshaft bearing	1	1	1
T1607	Thrust washer	1	1	1

GEARBOX SHAFTS AND GEARS (D7727 onwards)

T1608	LAYSHAFT COMPLETE (20T — Std.)	1	1	1
T1610	LAYSHAFT COMPLETE (18T — W.R.)	A	A	A
T1609	LAYSHAFT COMPLETE (22T — C.R.)	A	A	A

N.B.—To convert to close ratio from standard ratio use CP193

GEARBOX SELECTOR MECHANISM

T408/9	Gearchange quadrant	1	1	1
T1270	FOLDING KICKSTARTER	1	1	1
T402	Clutch operating arm	-	1	1

CLUTCH

T1560	Clutch spring (strong)	-	-	4
-------	----------------------------	-----	-----	-----	-----	---	---	---

FRAME

F4846	Front frame	1	1	1
-------	-----------------	-----	-----	-----	-----	---	---	---

ENGINE AND GEARBOX FITTINGS

F4569	Flanged nut (D7727 onwards)	1	1	1
F4746	Eye bolt ... (" ")	1	1	1
GS203	Plain washer (" ")	4	4	4
E1310	Nut ... (" ")	4	4	4
F4669	Abutment pin (" ")	2	2	2
S26-3	Spring washer (" ")	2	2	2
S1-51	Nut ... (" ")	2	2	2
F3599	Bracket — Rear engine plate to mudguard	-	1	1
F5049	Bracket — Rear engine plate to oil tank	-	1	1
F2335	Bolt	-	2	2
S26-3	Spring washer	-	2	2
S1-51	Nut	-	2	2

Page 43	CHAINCASE AND ALTERNATOR		6T	TR6	T120
47164	Stator RM19	1	-	-
47162	Stator RM19	-	1	1
47183	Stator RM19 (U.S. Models)	-	A	A
E4123	Stud (1 $\frac{3}{32}$ in. O.A.) for Stator	3	-	-
T1651	Outer chaincase	1	-	-
E3440	Screw (1 $\frac{1}{16}$ in. U.H.)	4	-	-
E3444	Screw (2 $\frac{1}{2}$ in. U.H.)	4	-	-
D433	Rear chain ($\frac{5}{8}$ in. \times $\frac{3}{8}$ in. \times 98 L)	1	1	1

Page 45	EXHAUST PIPES AND SILENCERS				
E4409	Left-hand exhaust pipe	1	1	-
E4410	Right-hand exhaust pipe	1	1	-
E2271	Clip	2	2	-
TE164D	"D" washer	2	2	-
TE164E	Bolt (1 $\frac{3}{16}$ in. U.H.)	2	2	-
TE164C	"D" nut	2	2	-
E4413	Silencer	1	-	-
E4174	Left silencer	-	-	1
E4175	Right silencer	-	1	1
E4107	Mute	-	1	2
H689	Screw	-	1	2
H691	Nut	-	1	2

Page 47	TELESCOPIC FORKS 6T				
H1422	FRONT FORK ASSEMBLY (SIDECAR)	A	-	-
H1322	LEFT BOTTOM MEMBER C/W CAP	1	-	-
H1323	RIGHT BOTTOM MEMBER C/W CAP	1	-	-
H1325	Spacing bobbins	2	-	-
H1326	Stud	2	-	-

Page 49	NACELLE, HEADLAMP AND SWITCHES				
70163	Horn	1	-	-
H1420	Horn bracket	1	-	-
F4771	Bolt ($\frac{1}{2}$ in. U.H.)	2	-	-
GS299	Serrated washer	2	-	-
F3799	Nut	2	-	-
54094328	Wiring harness	1	-	-

Page 53 **FRONT WHEEL 6T** —Read as for T110 on Page 55 with the undermentioned amendments.

Page 55	FRONT WHEEL T110, TR6 & T120 (D7727 onwards)				
W1410	LEADING BRAKE SHOE	1	1	1
W1411	TRAILING BRAKE SHOE	1	1	1
W1414	Brake lining	1	1	1
W1415	Pivot pad	2	2	2

Page 57	REAR WHEEL —For T120 read as for TR6 (D7727 onwards)				
W1406	LEADING BRAKE SHOE	} In pairs replace W93	1	1	1
W1407	TRAILING BRAKE SHOE		1	1	1
W1415	Pivot pad		2	2	2

QUICKLY DETACHABLE REAR WHEEL—For T120 read as for TR6 (D7727 onwards)

							6T	TR6	T120
W1406	LEADING BRAKE SHOE	} In pairs replace W93	1	1	1
W1407	TRAILING BRAKE SHOE		1	1	1
W1415	Pivot pad		2	2	2

PETROL TANKS

Note: T120 Models were fitted with either 3 or 4 gallon tanks as required.

F3220	Filler cap	~	1	-
F4971	Petrol tap	1	1	1
F4972	Petrol tap with reserve tube	1	1	1
F4916	Tank securing strap (3 Gal.)	(D16693 onwards)	1	1	1
F4917	Tank securing strap (4 Gal.)	" "	1	1	1
F4918	Tank strap sleeve	" "	2	2	2
F4919	Tank strap sleeve	" "	2	2	2

OIL TANK

F5067	Oil tank	~	1	-
F5066	Oil tank	-	-	1
F4985	FILLER CAP	-	1	1
F5051	Stud	-	1	1
F5049	Bracket	-	1	1
F2335	Bolt	-	2	2
S26-3	Spring washer	-	3	3
S1-51	Nut	-	2	2
F4110	Cap	-	2	2
F967	Rubber	-	1	1
F3815	Spigoted rubber	-	1	1
F4111	Bolt	-	1	1
—	Locking wire	as required		
F5050	Stud	-	1	1
T224	Nut	-	1	1
F3814	Cup	-	3	3
F967	Rubber	-	2	2
F4108	Spigoted rubber	-	2	2
W1058	Self-lock nut	-	2	2

BATTERY CARRIER AND TOOL BOX

F4905	BATTERY CASE AND TOOL BOX (D9660 onwards)	...	-	-	1
-------	---	-----	---	---	---

PANELS AND TWINSEAT

F4897	Reinforcing strip, lower panel fixing	1	-	-
F4715	Philips screw — reinforcing strip	2	-	-
F4717	Self-locking nut	2	-	-

CONTROL CABLES

								6T	TR6	T120
D416	FRONT BRAKE CABLE	1	-	-
F5203	Throttle cable junction box clip to frame	-	-	2
E3220	Clip screw	-	-	1
GS299	Clip screw washer	-	-	1
H745	Clip screw nut	-	-	1

CARBURETTER 6T, T110, TR6

376/285	CARBURETTER (D11193 onwards)	1	-	-
376/257	CARBURETTER " "	-	-	2
376/100	Main jet 220 (D11193 onwards)	1	-	-
376/060	Throttle valve (4 cutaway) (D11193 onwards)	-	-	1
F5039	Petrol pipe assembly	-	-	1
F4720	Petrol pipe	1	1	-

DISTRIBUTOR AND COIL

54441582	External replacement condenser (Coil bracket to C.B. terminal)	A	-	-
----------	---	-----	-----	-----	-----	-----	-----	---	---	---

HEADLAMP AND WIRING HARNESS TR6 & T120

E4515	Switch cover (for 41 SA switch)	-	A	A
34289	Lighting switch (88 SA)	-	1	1
F5020	Left switch bracket	-	1	1
F5021	Right switch bracket	-	1	1
54930007	Replacement harness socket (Lighting) (To convert from 41 SA switch to 88 SA type)	-	A	A
54930000	Harness (incorporating headlamp plug and 88 SA switch socket with Lucas stop switch connectors)	-	1	1
58878	Headlamp with 2 AR ammeter and socket connection	-	1	1
36296	Ammeter 2 AR	-	1	1
E3050	Ammeter rubber sealing ring (Lucas 523968)	-	A	A
H1413	Ammeter blanking disc	-	A	A
58934	Headlamp complete (with 2 AR ammeter)	-	1	1
862217	Headlamp rubber grommet, cable entry	-	1	1
54931221	Harness (to suit 58934 Headlamp, 88 SA switch, 49072 rectifier and 34381 stop lamp switch) deleting plug and socket at headlamp D18419 onwards	-	1	1
70163	Horn, type 8H	-	1	1
F4771	Horn fixing bolt	-	2	2
GS299	Serrated washer	-	2	2
F3799	Nut, horn fixing bolt	-	2	2

SPEEDOMETER, TAIL LAMP AND RECTIFIER

					6T	TR6	T120
SC3304/24	Speedometer head (125 m.p.h.) (D7727 onwards)	1	-	-
SC3304/25	Speedometer head (190 k.p.h.) (" ")	A	-	-
SC5301/09	Speedometer head (125 m.p.h.) (" ")	-	1	-
SC5301/16	Speedometer head (190 k.p.h.) (" ")	-	A	-
SC5301/26	Speedometer head (140 m.p.h.) (" ")	-	-	1
SC5301/18	Speedometer head (240 k.p.h.) (" ")	-	-	A
34381	Stop lamp switch (Lucar connectors)	1	1	1
F4844	Crinkle washer (Rectifier leads — for 47132 rectifier)	3	3	3
49072	Silicon rectifier (D18419 onwards)	1	1	1
F5338	Rectifier fixing nut (Lucas 156596)	1	1	1
54942078	Lucar Terminal (service conversion)	3	3	3
54190042	Lucar Terminal cover (service conversion)	3	3	3